

DEPARTMENT OF DEFENSE

**JOINT INSPECTOR GENERAL
INSPECTIONS GUIDE**

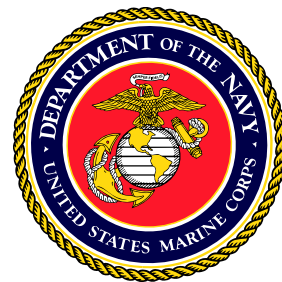

Rev 1

Joint IG Inspections Guide

Table of Contents

Chapter 1	Introduction	1-1
Chapter 2	Roles and Responsibilities of a Joint Inspector General	2-1
	Section 2.1 Roles and Responsibilities	2-2
	Section 2.2 Joint and Expeditionary Mindset	2-5
	Section 2.3 Joint Operating Environment	2-7
Chapter 3	Approaches to Joint Command Inspections	3-1
	Section 3.1 Quality Standards for Inspections	3-2
	Section 3.2 Inspection Selection Process	3-12
	Section 3.3 Inspection Approaches	3-15
	Section 3.4 Basic Elements of an Inspection	3-17
	Section 3.5 Root Cause Analysis Model	3-18
Chapter 4	Joint IG Inspections Process	4-1
Chapter 5	Preparation Phase	5-1
	Section 5.1 Step 1: Research	5-3
	Section 5.2 Step 2: Develop Concept	5-8
	Section 5.3 Step 3: Commander Approves the Concept	5-10
	Section 5.4 Step 4: Plan in Detail	5-17
	Section 5.5 Step 5: Train up	5-32
	Section 5.6 Step 6: Pre-inspection Visit	5-40
Chapter 6	Execution Phase	6-1
	Section 6.1 Step 7: Visit Commands	6-3
	Section 6.2 Step 8: In-process Review (IPR)	6-8
	Section 6.3 Step 9: Update Commander	6-20
	Section 6.4 Step 10: Analyze Results and Crosswalk	6-21
	Section 6.5 Step 11: Out-brief Proponent	6-32
Chapter 7	Completion Phase	7-1
	Section 7.1 Step 12: Out-brief the Commander	7-3
	Section 7.2 Step 13: Taskers	7-4
	Section 7.3 Step 14: Finalize Report	7-5
	Section 7.4 Step 15: Handoff	7-6
	Section 7.5 Step 16: Distribute the Report	7-7
	Section 7.6 Step 17: Schedule a Follow-up Inspection	7-8

Chapter 8	Conducting a Compliance Inspection	8-1
Section 8.1	Conducting a Compliance Inspection	8-2
Section 8.2	Developing Inspection Checklists for Compliance Inspections	8-5
Chapter 9	Special Topics/Interests	9-1
Section 9.1	Joint IG Intelligence Oversight Program	9-2
Section 9.2	Confidentiality and Use of Records in Joint IG Intelligence Oversight	9-8
Section 9.3	Personnel Accountability in Conjunction With Natural or Manmade Disasters	9-10
Section 9.4	Manager’s Internal Control Program	9-11
Section 9.5	Federal Voters Assistance Program	9-13
Appendix A	Glossary	A-1
Part I	Abbreviations and Acronyms	A-1
Part II	Definitions	A-4
Appendix B	References	B-1
Appendix C	Conducting Interviews	C-1
Appendix D	Conducting Sensing Sessions	D-1
Appendix E	Guidance on Collecting U.S. Person Information	E-1
Appendix F	Sample QIA and Quarterly Reporting Format and Instructions	F-1

Index

Chapter 1

Introduction

1. **Purpose.** The purpose of The Joint Inspector General Inspections Guide is to help Joint Inspectors General prepare, conduct, and complete effective inspections. The DoD Joint Inspector General Course uses this guide to teach the systemic inspections process and a tailored compliance inspection process. The systemic inspection process can also be tailored to meet a compliance inspection methodology.

2. **Joint Commanders and Joint Inspectors General.** Joint Commanders continually assess their organizations to determine the organization's capability to accomplish its missions. They accomplish this by analyzing and correlating evaluations of various functional systems such as training, logistics, personnel, resource management, command and control, intelligence, etc. A Joint IG inspection is one of many sources of information available to the Joint Commander. The Joint IG inspection function is the process of conducting inspections, developing and implementing inspection programs, and advising Joint Commanders, unit commanders, and Joint Command staff on inspection policy and results. Inspection reports ensure the continuity of operations and provide a baseline for follow-up inspections, inspection planning, and trend analysis.

One of the Joint Command Inspector General's (JCIG) four primary areas of responsibility is to conduct inspections at the request of the Joint Commander. Additionally, the Joint IGs will prepare and coordinate an inspection plan for each year. To develop this inspection plan, Joint IGs will identify inspection possibilities, evaluate the benefits expected from them, and then set priorities for projected inspections. There are many ways to identify possible topics for inspections (e.g., Joint Commander's guidance, the joint mission essential task list, trend analysis, input from functional staff proponents, quarterly training briefs, unit status reports, results of group interviews, results from other inspections, and results of previous IG inspections).

The Joint IGs must tailor their inspections to meet their Joint Commander's requirements. For inspections to be of value to the Joint Commander, the Joint IG must design them to collect information that will assist the Joint Commander in making decisions regarding the inspected organization or function. The Joint IG inspections will identify noncompliance; determine the magnitude of the deficiency; seek the root cause; pursue systemic issues; teach systems, processes, and procedures; identify responsibility for corrective action; spread innovative ideas and train those inspected.

Teaching and training is an integral part of the Joint IG functions of assisting, inspecting, and investigating and occurs during the course of the Joint IGs duties. Although the Joint IGs are not the primary trainers of Service members, they possess a reservoir of experience and knowledge to assist commanders in achieving disciplined and combat-ready units. The Joint IGs provide information about military systems, processes, and procedures; and assess the command climate while assisting, inspecting, and investigating. The Joint IGs pass on lessons learned to enable others to benefit from experience.

3. **Inspections.** The fundamental purpose of inspections is to assess, assist, and enhance the ability of a command or component to prepare for and perform its assigned mission. The

command's mission shall be the focus of the inspection. Inspections will identify root causes of problems, particularly those beyond the capability of the commander to solve. The Joint IG Inspection program is built upon five basic principles. Inspections must be:

- Purposeful
- Coordinated
- Focused on feedback
- Instructive
- Followed up

Joint IG inspectors apply either a compliance-oriented or a systemic approach to inspections. Compliance-oriented inspections measure the readiness of Joint organizations and their respective functions against established standards. Inspectors determine why a Joint command or organization failed to meet a standard by asking open-ended questions of the individuals involved to determine the root cause(s) for non-compliance. The use of strict checklists is discouraged because they do not allow for follow-on questions that lead to the discovery of root causes. Checklists may be useful as a guide while conducting compliance-type inspections. See Section 8.2 for a further discussion of checklists.

The systemic approach involves larger problems associated with individual systems, functions, and programs within the Joint command. Functional inspections based on a systems approach are typically narrow in focus and aimed at broader-based issues affecting more than one Joint command or structure. This narrow scope allows IGs to take a systemic look at a topic, function, issue, or problem area and then determine the root cause(s) of the deficiencies with the goal of fixing the system.

4. This Guide as a Handbook. This guide is designed to serve as a ready reference and step-by-step handbook allowing a Joint IG to inspect a topic with systemic implications or to conduct a compliance-oriented inspection of a unit or command. Many of the techniques and formats offered herein are not mandatory for use but instead offer all Joint IGs a common frame of reference and a compilation of "best practices" used by IGs throughout the Department of Defense and other defense agencies. This guide supports and complements The Joint Inspector General Concept and System Guide.

5. Sample Joint Inspector General Memoranda and Final Report Outline. The sample formats used in this guide appear in subsequent chapters.

6. Format for Sample Memorandums. This guide contains numerous sample memorandums that adhere to the format requirements outlined in Joint Staff Manual (JSM) 5711.01D, Joint Staff Correspondence Preparation. However, in an effort to save space and paper, some of the required font sizes and spacings have been compressed. Refer to JSM 5711.01D for the precise format specifications.

7. Questions and Comments. For questions or comments concerning this guide, please contact the staff at the DoD Joint Inspector General Course.

8. References. Required and related publications are listed in Appendix B.

Chapter 2

Roles and Responsibilities of a Joint Inspector General

Section 2.1 Roles and Responsibilities

Section 2.2 Joint and Expeditionary Mindset

Section 2.3 Joint Operating Environment

Section 2.1

Joint IG Roles and Responsibilities

1. Purpose. This section describes the roles and responsibilities of an Inspector General in a Joint environment.

2. Roles. The Joint Command Inspector General (JCIG) and all Joint IGs are an extension of the eyes, ears, voice and conscience of the Joint Commander. The Inspector General is a personal staff officer who provides the Joint commander with a sounding board for sensitive issues and serves as a fair, impartial, and objective fact-finders and problem solvers. JCIGs are honest brokers whose primary functions include training, inspecting, assisting, and investigating. Joint IGs shall inform the Joint Commander of his/her observations, findings, and impressions on all aspects of the command.

3. Responsibilities.

a. Perform investigative, inspection, evaluation, assistance, teaching, and training functions as directed by the Commander of the Joint Command and make inquiries into any matter within the scope of the Commander's authority, consistent with DoD Directive 5106.01, "Inspector General of the Department of Defense (IG DoD), and Title 5, USC, Appendix 3 "Inspector General Act of 1978."

b. Report on the state of the economy, efficiency, discipline, morale, training, and readiness throughout the command as directed by the Joint Commander or in support of the Joint Commander's intent, consistent with DoD Directive 5106.01, "Inspector General of the Department of Defense (IG DoD), and Title 5, USC, Appendix 3 "Inspector General Act of 1978."

c. Coordinate with the Inspector General of the Department of Defense to address issues of mutual concern that involve their organization and other commands.

d. Monitor and report on Joint Command intelligence oversight programs in those units/organizations assigned, attached, or under the administrative control of the Joint Command according to DoD Directive 5240.1, "DoD Intelligence Activities", DoD 5240.1-R, "Procedures Governing the Activities of DoD Intelligence Components that Affect United States Persons" and CJCSI 5901.01, "Joint Staff Inspector General Responsibilities, Procedures, and Oversight Functions."

f. Recommend actions to correct deficiencies identified during investigations, inspections/evaluations, and assistance visits, and monitor the progress of approved corrective actions.

4. Relationships. In the performance of assigned responsibilities and functions, Joint Command Inspectors General shall:

- a. Report directly to either the Joint Commander or to the Deputy Joint Commander. This IG command and reporting relationship may not be further delegated.
- b. Serve their respective Joint Commanders and support the Soldiers, Sailors, Airmen, Marines, Coast Guardsmen (when assigned or attached), DoD contractors (non-contract issue), and DoD civilian employees within the command.
- c. Joint IGs must be sufficiently independent so that personnel requesting Joint IG assistance will continue to do so even when the complainant feels that the commander may be the problem.
- d. Coordinate Inspector General activities with the Inspector General of the Department of Defense, the Joint Staff Inspector General, and Inspectors General of the Military Departments, as appropriate. Notify the Military Service concerned of initiation and completion of investigative actions in accordance with Military Service requirements.
- e. Refer to the appropriate official for disposition of any matter outside the authority of the Joint Command Inspector General that may become evident during the conduct of investigations, inspections/evaluations, or assistance visits.
- g. Select and train Joint IG staff members. The Joint IG may afford the IG of the nominee's Military Service the opportunity to comment on the qualifications and suitability of any prospective Joint IG staff member.

5. Joint IG Wartime Responsibilities. The basic IG functions shall remain the same in war and peace. However, the focus during military operations must be on the tasks and systems that relate directly to readiness and operations.

a. Assignment of Joint IG Responsibilities in Wartime Operations. As directed by the Joint Commander and described in operational plans and orders, Joint IGs may have an operational mission. To maintain situational awareness, the Joint IGs must understand the Joint Commander's intent and concept of the operation.

b. Joint IG Wartime Deployment Plan. As required by the Joint Commander, the Joint IG will formulate a plan to support deployed operations. This plan should include anticipated Joint IG actions during each phase of the operation, such as mobilization, deployment, containment, preparation for combat, redeployment, and reconstitution. The Joint IGs will continue to address morale and welfare issues, medical issues, family issues, civilian employee or other civilian issues and concerns, and other issues consistent with the fundamental missions of the IG system.

c. Joint IG Wartime Planning. The Joint IGs must plan for provision of full-service operations in all joint command operations. The organization of a Joint IG office will vary depending on the status, location, and mission of that office. Considerations must be given to the need for both deployed and stay-behind capabilities in people and equipment. The following factors may be considered by Joint IGs in the planning process:

d. Deployable Joint IG Personnel. Identify the proper (deployable) mix of personnel to retain flexibility for deploying elements while maintaining adequate resources at the home station to meet supporting Joint IG requirements.

e. Reserve Augmentees. Identify reserve augmentees IG staffing needs. Reserve personnel requirements shall be identified in the mobilization Joint Manning Document.

f. Wartime Training Assessment for Reserve Component Personnel. Determine theater unique training requirements for reserve component personnel who will be identified upon activation. Those needs must be prioritized with other Joint Command training needs and accomplished as practicable.

g. Joint IG Coverage of Remote Areas or Significant Increases in Unit Strength. The Joint IG coverage must be provided to remote locations, units with significant increases in personnel strength, and Joint Task Forces. This coverage may be in the form of reach back, periodic visits, or another methodology (i.e., identify required IG personnel on Joint Manpower Documents).

h. Joint IG Coverage of Widely Dispersed Personnel. If the Joint IG determines that the theater of operations will be one where personnel will be widely dispersed, the Joint IG should indicate the methodology for Joint IG coverage in the operation plan/order.

i. Determination of Joint IG Bases of Operations. In accordance with applicable plans and the Commander's guidance, the Joint IG will determine the bases of operation required at the home station, staging bases, and deployed locations, to include the command posts from which the Joint IG will operate.

Section 2.2

Joint and Expeditionary Mindset

1. **Purpose.** This section describes the Joint and Expeditionary mindset.
2. **Joint and Expeditionary Mindset.** Recent history has shown that America's armed forces will fight and win this Nation's wars jointly. The current environment demands Services be expeditionary in nature and able to deploy quickly anywhere in the world. This means Joint Inspectors General (Joint IG) must be prepared to support the Joint commander as a multi-service force deploys forward.
3. **Staffing.** The Joint IG must consider the nature and scope of the IG support required in the area of operations and at home station. The Joint Table of Distribution (JTD) and Joint Table of Mobilization Document (JTMD) will dictate the size of the Joint IG staff. The IG must tailor the staff to address all required IG functions; inspections, investigations, intelligence oversight, teaching and training, and assistance, with a mix of trained IG personnel from the various Service branches. The trained IGs from other Services may need to employ their specific Services' IG systems in certain instances depending on the situation. If the Joint Task Force (JTF) is combined with and includes allied forces, the Joint IG will request IG representation from those international or coalition commands as necessary.
4. **Policy Guidance.** The Joint IG must use established Joint doctrine to determine the principal standards from which to inspect. Joint standards are found in Joint Publications 1-0 through 6-0; these doctrinal publications represent the major Joint systems in the Joint environment. Adherence to Joint Staff and DoD policy remain in effect. The Joint IG will need to review each Service's applicable policies when planning and conducting a compliance-type inspection. Below is a brief description of each Joint publication and its purpose:
 - a. Joint Publication 1-0, Personnel Support to Joint Operations, provides doctrine for planning, coordinating, and providing personnel support to Joint operations. It also provides information relating to the functions, authorities, and responsibilities of the combatant commander, Joint force commander and staffs, and the Service components as they relate to personnel management and selected activities that support the personnel needs of the Joint staff.
 - b. Joint Publication 2-0, Joint Intelligence, provides fundamental principles and guidance for intelligence support to Joint operations and unified action.
 - c. Joint Publication 3-0, Joint Operations, provides the doctrinal foundation and fundamental principles that guide the Armed Forces of the United States in the conduct of Joint operations across the range of military operations.
 - d. Joint Publication 4-0, Joint Logistics, provides doctrine for logistic support of Joint and multinational (allied and coalition) operations.

e. Joint Publication 5-0, Joint Operation Planning, provides doctrine for Joint operational planning throughout the range of military operations.

f. Joint Publication 6-0, Joint Communications System, presents approved doctrine for communications system support to Joint and multinational operations and outlines the responsibilities of Services, agencies, and combatant commands with respect to ensuring effective communications system support to commanders. It addresses how the communications system, in general, is to be configured, deployed, and employed to support the commanders of Joint forces in the conduct of Joint operations. Recognizing the complexities of Joint warfighting and the ongoing transformation to a network-enabled environment, the communications system is placed in the context of the Department of Defense's Global Information Grid.

5. **Communications.** The Joint IG must define and work within command lines. The Combatant Command (COCOM) is expected to maintain lines of communication between the established JTF IGs as well as Service IGs and the Joint Staff IG.

The JTF commander reports to the COCOM commander who has directing authority over the JTF; in turn, the JTF IG office must remain responsive to the COCOM IG office. The technical-channel relationship (dotted line) with the COCOM IG shows the interaction required with that office to remain updated on Joint policy or established COCOM policies. The COCOM IG will identify routine reports and information requirements from the JTF IG that feed into reports required from the COCOM IG by the commander. While reporting to the COCOM commander, the JTF may also continue to maintain a relationship with the JTF's Service headquarters. (See Figure 2-1)

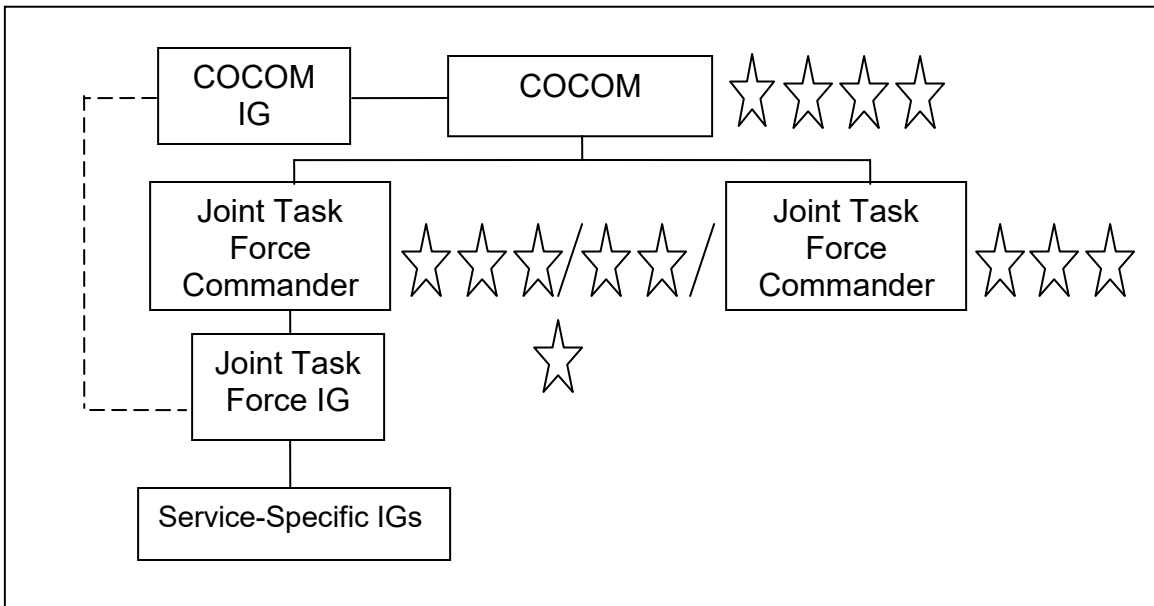

Figure 2-1
Joint IG Lines of Communication

Section 2.3

The Joint Operating Environment

1. **Purpose.** This section describes the role of the Inspector General in Joint Operations.
2. **Joint Operating Environment.** Combatant Commanders are assigned missions and tasks based on their geographic areas of responsibility or on their functional capabilities. The Joint Strategic Capabilities Plan (JSCP) provides guidance to the COCOM and the Services to accomplish missions and tasks based on current military capabilities. The JSCP provides a coherent framework for capabilities-based military tasks assigned by the National Command Authorities (NCA), treaty obligations, or other documents supporting the Unified Command Plan (UCP).

The COCOM normally operates at the strategic level of war, applying the military element of power in coordination with the other elements of national power, in order to achieve the desired military end-state. This end-state will adhere to the guidelines within the strategic end-state determined by national security or strategic military objectives and guidance. A theater of operations commander (e.g., unified commander, sub-unified commander, or JTF commander), however, operates mostly at the operational level of war, applying military power in the designated theater of operations toward the strategic military objectives assigned by the geographic COCOM or NCA.

Figure 2-2 provides a systems view of the Joint environment where a matrix-type environment ensues. Services, Supplies, Equipment, Training, Organization, and Administration are fed into Joint systems such as Personnel, Intelligence, Operations, Logistics, and Operational Planning. The COCOM and JTF commanders work within the guidelines and parameters of Joint policy and guidance as they apply to these systems. The Joint IG must understand the Joint environment to determine where systemic issues block the system and negatively impact mission readiness. The Joint IG is responsible for informing the Joint commander when ineffective processes appear to exist in the Joint system. Upon the Joint commander's approval, the Joint IG will develop an inspection plan to uncover the root cause(s) of the problem. Recommendations can range from policy change/review from the higher echelon proponent of the policy to enhanced training within the command or component.

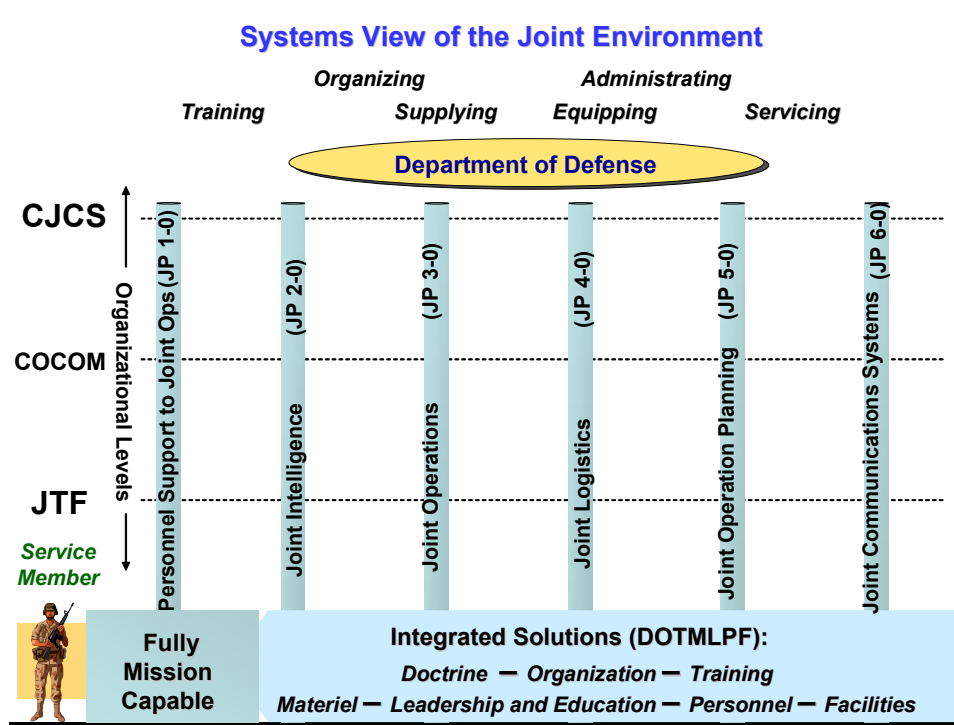

Figure 2-2
Systems View of the Joint Environment

3. **The Universal Joint Task List.** The Universal Joint Task List (UJTL) identifies “what” is to be performed in terms common to the Joint Staff, Services, COCOM and components, activities, Joint organizations, and agencies responsive to the Chairman of the Joint Chiefs of Staff (CJCS). The UJTL task description does not address “how” a task is performed (found in Joint doctrine/Joint tactics, techniques, and procedures (JTTP)), or “who” performs the task (found in the commander’s concept of operations and Joint doctrine/JTTP).

Joint tasks describe, in broad terms, the current and potential capabilities of the Armed Forces of the United States. Joint tasks are actions or processes accomplished by a Joint organization under Joint command and control using Joint doctrine. They are assigned by Joint force commanders to be performed by Joint forces, staffs, and integrated service components. The CJCS manual (CJCSM 3500.03) provides an overall description of Joint tasks applied at multiple levels of command, i.e., strategic national, strategic theater, operational, and tactical (each Service publishes its own task list to supplement the UJTL).

The Commander’s approved measures and criteria of performance comprise the task standard to describe how well a Joint organization or force must perform a Joint task under a specific set of conditions. The Joint force commander uses criteria and measures to establish task standards based on mission requirements. These standards, when linked to conditions, provide a basis for planning, conducting, and evaluating military operations as well as training events.

4. **Joint Training and Readiness.** Training is a key element of readiness. Military readiness is defined in two parts: unit and joint. Readiness is “the ability of US military forces to fight and meet the demands of the national military strategy” and is the synthesis of two distinct but interrelated levels:

- **Unit readiness** - the ability to provide capabilities required by the COCOM to execute their assigned missions. Unit readiness is derived from the ability of each unit to deliver the outputs for which it was designed.

- **Joint readiness** - the COCOM and JTF Commander’s ability to integrate and synchronize ready combat and support forces to execute assigned missions.

The Joint Command IG must understand the Joint readiness requirements in order to inspect properly and assess mission readiness of the COCOM and JTF.

Chapter 3

Approaches to Joint Command Inspections

- Section 3.1 Quality Standards for Inspections
- Section 3.2 Inspection Selection Process
- Section 3.3 Inspection Approaches
- Section 3.4 Basic Elements of an Inspection
- Section 3.5 Root Cause Analysis Model

Section 3.1

Quality Standards for Inspections

Inspection organizations should strive to conduct their operations in the most efficient and effective manner possible, which serves to enhance the credibility of the organizations. The inspection function at each Department/Agency is tailored to the unique mission of the respective Department/Agency. It is the responsibility of each Office of Inspector General to develop internal written procedures to guide the actual conduct of inspection work. These procedures should include the appropriate controls necessary to ensure compliance with the "Quality Standards for Inspections," as well as the Inspector General Act of 1978, as amended, and any other legislation or regulations applicable to an organization's operations.

As used throughout these standards, the term "inspection" is defined as a process that evaluates, reviews, studies, and/or analyzes the programs and activities of a Department/Agency for the purposes of providing information to managers for decision making; making recommendations for improvements to programs, policies, or procedures; and identifying where administrative action may be necessary. The term "inspector" is used generically to refer to the individual conducting such work.

The following standards are established by the President's Council on Integrity and Efficiency(PCIE) and the Executive Council on Integrity and Efficiency (ECIE) to guide the conduct of all inspection work performed by Offices of Inspector General (OIGs). The PCIE and ECIE endorse the need for "Quality Standards for Inspections" and encourage the consistent application of these standards throughout the Inspector General community.

1. Competency -

- a. The standard for inspection work is:

The staff assigned to perform inspection work should collectively possess adequate professional competency for the tasks required.

- b. The personnel conducting an inspection should collectively have the knowledge, skills, abilities, and experience necessary for the assignment. which should include the following:

1) Knowledge of evaluation methodologies; familiarity with the concepts, processes, and assumptions of the program or activity being inspected; the capacity to conduct a broad interdisciplinary inquiry; knowledge of qualitative and quantitative analysis; writing and oral briefing skills; information technology related capabilities; and knowledge of Inspector General statutory requirements and directives.

2) The ability to develop a working familiarity with the organizations, programs, activities, and/or functions identified for inspection. When reviewing

technical or scientific topics, it may be appropriate to use the services of a subject matter expert.

3) Managerial skills for supervisors, team leaders, and lead inspectors.

2. Independence -

a. The standard for inspection work is:

In all matters relating to inspection work, the inspection organization and each individual inspector should be free both in fact and appearance from personal, external, and organizational impairments to independence.

b. Inspection organizations and inspectors should be alert to possible impairments to independence and should avoid situations that could lead reasonable third parties to conclude that the inspection organization or inspectors are not independent and, thus, are not capable of exercising objective and impartial judgment. Impairments to independence, either in fact or appearance, need to be resolved in a timely manner.

Inspection organizations should not provide non-inspection services that involve performing management functions or making management decisions, nor should they inspect their own work or provide non-inspection services.

c. Three general types of impairments to independence:

1) Personal Impairments - Result from relationships and beliefs that might cause inspectors to limit the extent of an inquiry, limit disclosure, or weaken or slant inspection findings in any way. Inspectors are responsible for notifying the appropriate officials within their respective inspection organizations if they have any personal impairment to independence.

2) External Impairments - Occur when inspectors are deterred from acting objectively and exercising professional skepticism by pressures, actual or perceived, from management or employees of the inspected entity, oversight organizations, or other factors external to the OIG. When external factors restrict an inspection or interfere with an inspector's ability to form objective opinions and conclusions and the inspector cannot remove the limitation, the inspector should report the limitation in accordance with the respective OIG's internal policies and procedures.

3) Organizational Impairments – Occurs when an OIG's ability to perform work and impartially report the results are affected by its placement within a Department/Agency or the structure of the Department/Agency. Inspection organizations within OIGs established by the Inspector General Act of 1978, as amended, derive organizational independence from the statutory safeguards to independence established by the Act. If an inspector believes there is an organizational impairment that could affect his/her inspection work, he/she should report the matter in accordance with the respective OIG's internal policies and procedures.

3. Professional Judgment -

- a. The standard for inspection work is:

Due professional judgment should be used in planning and performing inspections and in reporting the results.

b. Professional judgment requires inspectors to exercise reasonable care and diligence and to observe the principles of serving the public interest and maintaining the highest degree of integrity, objectivity, and independence in applying professional judgment to all aspects of their work. Inspectors should use professional judgment in selecting the type of work to be performed and the standards that apply to the work; defining the scope of work; selecting the inspection methodology; determining the type and amount of evidence to be gathered; and choosing the tests and procedures for their work. Inspectors are required to exercise professional skepticism throughout the inspection. Inspectors should use the knowledge, skills, and experience called for by their profession to diligently gather evidence and objectively evaluate its sufficiency, competency, and relevancy.

4. Quality Control –

- a. The standard for inspection work is:

Each OIG organization that conducts inspections should have appropriate internal quality controls for that work.

b. Each OIG should develop and implement written policies and procedures for internal controls over its inspection processes/work to provide reasonable assurance of conformance with organizational policies and procedures, the “Quality Standards for Inspections,” and other applicable policies and procedures.

A key aspect of inspection quality control is adequate supervision. Supervisors should work with inspection team members to reach agreement as to the work the team will do and how they are to proceed. The team also should have a clear understanding of the purpose of the inspection and what it is expected to accomplish. Supervisory reviews help ensure that:

- 1) The inspection is adequately planned;
- 2) The inspection work plan is followed, unless deviation is justified and authorized;
- 3) The inspection objectives are met; and
- 4) The inspection findings, conclusions, and recommendations are adequately supported by the evidence.

5. Planning –

- a. The standard for inspection work is:

Inspections are to be adequately planned.

b. The standard for inspection planning is intended to ensure that appropriate care is given to selecting inspection topics and preparing to conduct each inspection, to include coordinating inspection work and avoiding duplication. Additionally, the potential sensitivity or classification of information needs to be a consideration throughout the inspection process. In pursuing this standard, the following should be appropriately addressed:

1) Coordination - Inspection planning includes coordinating planned activities with other inspection, audit, and investigative entities, as well as appropriate organizations that could be affected by the activities. Internal and external constraints should be considered when planning inspection activities. Inspectors should be flexible in their plans, within reasonable limits. Any internal reviews performed by the entity to be inspected or by outside professional organizations should be considered and reviewed to determine applicability to the inspection. In addition, when an inspection addresses a topic that is cross-cutting or affects other governmental organizations, the OIG may consider conducting a joint or coordinated review with those other organizations' OIGs.

2) Research - Consistent with the inspection objectives, inspection research includes a review of existing data, discussions with program and other appropriate officials, literature research, and a review of pertinent websites and other internet accessible materials to gather information that will facilitate understanding of the program or activity to be inspected. Research should help to identify the criteria applicable to the evaluation of the program or activity.

3) Work plan - An inspection work plan should clearly define the inspection objective(s), scope, and methodology. It may also include inspection time frames and work assignments. Adequate planning also entails ensuring that sufficient staff with the appropriate collective knowledge, skills, abilities, and experience is assigned to the inspection effort. As work on an inspection progresses, the work plan may need revision to address new information.

6. Data Collection and Analysis –

- a. The standard for inspection work is:

The collection of information and data will be focused on the organization, program, activity, or function being inspected, consistent with the inspection objectives, and will be sufficient to provide a reasonable basis for reaching conclusions.

b. With regard to **collecting data**, the following guidance should be addressed whenever appropriate:

1) The sources of information should be described in the supporting documentation in sufficient detail so that the adequacy of the information, as a basis for reaching conclusions, can be assessed.

2) Information should be of such scope and selected in such ways as to address pertinent questions about the objectives of the inspection and be responsive to the informational needs and interests of specified audiences.

3) The procedures and mechanisms used to gather information should ensure that the information is sufficiently reliable and valid for use in meeting the inspection objectives.

4) Confidentiality, as appropriate, should be afforded to sources of information consistent with the Inspector General Act of 1978, as amended; the internal policies of each OIG; and other applicable laws and statutes.

5) Appropriate safeguards should be provided for sensitive information, such as personal and proprietary data, as well as classified information.

c. In **analyzing data**, the following guidance should be considered:

1) Data should be reviewed for accuracy and reliability; and, if necessary, the techniques used to collect, process, and report the data should be reviewed and revised to ensure the accuracy and reliability of inspection results.

2) Qualitative and quantitative information gathered in an inspection should be appropriately and logically presented and documented in work papers, to ensure supportable interpretations.

3) Inspection procedures should provide for supervisory review and other safeguards to protect the inspection findings and reports against distortion by the personal feelings and biases of any party to the inspection.

4) The elements needed for a finding depend entirely on the objectives of the inspection. Thus, a finding or set of findings is complete to the extent that the inspection objectives are satisfied and the report clearly relates those objectives to the applicable elements of a finding.

7. Evidence –

a. The standard for inspection work is:

Evidence supporting inspection findings, conclusions, and recommendations should be sufficient, competent, and relevant and should lead a reasonable person to sustain the findings, conclusions, and recommendations.

b. Evidence may take many forms, including physical, testimonial, documentary, and analytical. Physical evidence is obtained by an inspector's direct review or observation of people, property, or events and should be appropriately documented. Testimonial evidence is obtained through inquiries, interviews, or questionnaires. Documentary evidence consists of created information, such as letters, contracts, grants, memorandums, and files. Analytical evidence includes computations, benchmarking, trending, comparisons, and rational arguments. The following guidelines should be considered regarding evidence:

- 1) Evidence should be sufficient to support the inspection findings. In determining the sufficiency of evidence, inspectors should ensure that enough evidence exists to persuade a knowledgeable person of the validity of the findings.
- 2) To be competent, evidence should be reliable and the best obtainable by using reasonable collection and evaluation methods.
- 3) Relevance refers to the relationship of evidence to its use. The information used to prove or disprove an issue must have a logical relationship with, and importance to, the issue being addressed.

8. Record Maintenance –

a. The standard for inspection work is:

All relevant documentation generated, obtained, and used in supporting inspection findings, conclusions, and recommendations should be retained for an appropriate period of time.

b. Supporting documentation is the material generated and collected as part of an inspection that, when effectively organized, provides an efficient tool for data analysis and a sound basis for findings, conclusions, and recommendations that address the inspection objectives. Supporting documentation should also provide:

- 1) A record of the nature and scope of inspection work performed; and
- 2) Information to supervisors and team leaders enabling them to properly manage inspections and evaluate the performance of their staff. Supervisory and team leader review should be evidenced in the inspection documentation.

c. Inspection organizations should establish policies and procedures for the safe custody and retention of inspection documentation. Inspection documentation should be retained and disposed of in accordance with applicable legal and administrative requirements and schedules. Documentation generated by the Department/Agency and used to support inspection findings, such as lengthy reports, could be retained by the Department/Agency so long as the OIG fully references these documents and is confident that the documentation in question could not be lost, destroyed, or altered.

9. Timeliness –

a. The standard for inspection work is:

Inspections should strive to deliver significant information to appropriate management officials and other customers in a timely manner.

b. To be of maximum use, inspections need to be conducted and reporting needs to be completed in a timely manner. This helps to ensure the work is current and relevant. During an inspection, it may be appropriate to provide interim reporting of significant matters to appropriate officials. Such reporting is not a substitute for a final report, but it does serve to alert the appropriate officials to matters needing immediate attention, so corrective action may be initiated. The following guidance should be considered regarding timeliness:

- 1) Time frames should be flexible in response to changing priorities.
- 2) Time frames established during planning are subject to change due to unforeseen circumstances.

10. Fraud, Other Illegal Acts, and Abuse –

a. The standard for inspection work is:

In conducting inspection work, inspectors should be alert to possible fraud, other illegal acts, and abuse and should appropriately follow up on any indicators of such activity and promptly present associated information to their supervisors for review and possible referral to the appropriate investigative office.

b. Inspectors should be alert to any indicators of fraud, other illegal acts, or abuse. While the identification of such activities is not usually an objective of an inspection, it is necessary to have a clear understanding of the action required if such circumstances are discovered. Inspectors should be aware of vulnerabilities to fraud and abuse associated with the area under review in order to be able to identify possible or actual illegal acts or abuse that may have occurred. In some circumstances, conditions such as the following might indicate a heightened risk of fraud:

- 1) The absence of internal controls.
- 2) Inadequate “separation of duties,” especially those that relate to controlling and safeguarding resources.
- 3) Transactions that are out of the ordinary and are not satisfactorily explained or documented.
- 4) Missing or altered documents or unexplained delays.
- 5) False or misleading information.
- 6) A history of impropriety.

c. Inspectors should exercise professional judgment so as to ensure they do not interfere with potential investigations and/or legal proceedings. If possible illegal

behavior arises, inspectors should promptly present such information to their supervisors for review and possible referral to the appropriate investigative office.

11. Reporting –

- a. The standard for inspection work is:

Inspection reporting shall present factual data accurately, fairly, and objectively and present findings, conclusions, and recommendations in a persuasive manner.

b. Reporting should be timely, complete, accurate, objective, convincing, clear, and concise. The content of the reporting will be affected by the specific means used and the purpose it is serving. Inspection reporting normally should describe the objective(s), scope, and methodology of the inspection and state that the inspection was conducted in accordance with the “Quality Standards for Inspections.” Also, inspection reporting should provide the reader with the context in which the subject matter being inspected should be viewed to help ensure the focus is not too narrowly drawn and to give clearer understanding of the impact of any report recommendations. Reporting language should be clear and concise and written in terms intelligible to the intended recipients and informed professionals.

d. Findings should be supported by sufficient, competent, and relevant evidence. Conclusions should be logical inferences about the inspected program or activity based on the inspection findings. Typically, each finding requiring corrective action should be addressed by one or more recommendations directed to the management official(s) who have the authority to act on them. Recommendations should be crafted in a manner that lays out what needs to be corrected or achieved. When appropriate, inspectors should solicit advance review and comments from responsible officials regarding the content of the report and should include the comments or a summary thereof in the report.

e. Care must be taken to ensure that, as applicable, the confidentiality of individuals providing information is appropriately maintained in the inspection reporting process.

f. Written inspection reports should be distributed to the appropriate officials responsible for taking action on the findings and recommendations. Further distribution will be subject to the internal policies of each OIG and fully comply with all requirements contained in the Privacy Act; the Freedom of Information Act; and security and other applicable laws, regulations, and policies.

12. Follow-up –

- a. The standard for inspection work is:

Appropriate follow-up will be performed to assure that any inspection recommendations made to Department/Agency officials are adequately considered and appropriately addressed.

b. Ultimate inspection success depends on whether necessary corrective actions are actually completed. Therefore, each OIG should take steps, as necessary, to determine whether officials take timely, complete, and reasonable actions to correct problems identified in inspection reports.

Follow-up helps ensure actions are undertaken and completed within a reasonable time. Management notification that an action has been completed within the agreed-on time constitutes reasonable assurance and can be the basis for “closing” an action for follow-up purposes. However, the OIG should perform follow-up work to verify whether agreed-on corrective actions were fully and properly implemented.

13. Performance Measurement –

a. The standard for inspection work is:

Mechanisms should be in place to measure the effectiveness of inspection work.

b. Performance measurement should focus on the outputs and the resultant outcomes from inspection work. The nature and extent of performance measurement will be affected by a number of factors, such as the size and structure of the organization performing inspections. Optimum performance measurement captures the impact of an inspection and may include such things as monetary savings, enforcement of laws, or legislative change.

14. Working Relationships and Communication –

a. The standard for inspection work is:

Each inspection organization should seek to facilitate positive working relationships and effective communication with those entities being inspected and other interested parties.

b. The OIG and the Department/Agency should strive to do the following:

1) Foster open communication at all levels. With limited exceptions, primarily related to investigative-type work, the OIG should keep the Department/Agency advised of its work and its findings on a timely basis and strive to provide information helpful to the Department/Agency at the earliest possible stage. Surprises are to be avoided.

2) Interact with professionalism and respect. OIGs should act in good faith.

3) Recognize and respect the mission and priorities of the Department/Agency. Each OIG should work to carry out its functions with a minimum of disruption to the primary work of the Department/Agency.

4) Be thorough, objective, and fair. The OIG must perform its work thoroughly, objectively, and with consideration to the Department's/Agency's

point of view and should recognize Department/Agency successes in addressing challenges or issues.

5) Be engaged. While maintaining OIG statutory independence of operations and recognizing that OIGs need to conduct work that is self-initiated, congressionally requested, or mandated by law, OIGs should interact with Department/Agency management to identify any specific needs or priorities management may have regarding the reviews to be conducted by the respective OIG.

6) Be knowledgeable. The OIG will continually strive to keep abreast of Department/Agency programs and operations, and Department/Agency management should be kept appropriately informed of OIG activities and concerns being raised in the course of OIG work.

7) Provide feedback. OIGs should implement mechanisms, both formal and informal, to ensure prompt and regular feedback.

c. Specific to inspection work, inspectors should appropriately communicate information about the inspection process and the nature of the inspection to the various parties involved in the inspection to help them understand such things as the inspection objective(s), time frames, data needs, and reporting process. Inspectors should use their professional judgment and comply with their respective organization's policies and procedures to determine the form, content, and frequency of communication. Communication should be appropriately documented in the associated inspection records.

Section 3.2

Inspection Selection Process

1. **Purpose.** The purpose of this section is to explain the Inspection Selection Process and the scheduling of Joint IG Inspections.
2. **Selecting Inspections.** The Joint IG should always plan inspections by keeping the precepts of long-range planning in mind. Inspection planning can become a delicate balancing act between long-range planning and remaining flexible to the Joint commander's changing needs.
3. **Striking the Balance.** The benefits of long-range planning are obvious. A planned inspection keeps the Joint IG from disrupting a unit's training schedule. Most long-range inspection plans, once published, do not specify the units that the inspection team plans to visit. However, units within the Joint command can anticipate the possibility of receiving a Notification Letter from the inspection team during the established time periods. Notifications should not cause units to alter their training plans since the Joint IG team needs to see things exactly as they are happening.

Planned but unannounced inspections (where the units are not, and will not be, identified) are an acceptable way of planning inspections, but the best planning method is to announce all inspection topics in advance with some general guidance about the types of units or agencies the inspection team may visit. The commander may alter the inspection plan with little notice if an important inspection need suddenly arises. The inspector must anticipate such an occurrence and prepare to adjust the long-range inspection plan accordingly. The Joint IG may have to recommend to the commander that an ongoing inspection stop temporarily (or permanently) or that the scheduled inspection topics on the prioritized inspection list be delayed. The Joint IG must learn how to balance these long-range and short-notice aspects of inspection planning.

4. **Prerequisites for the Joint IG.** The Joint IG cannot remain behind a desk in the IG shop if he or she plans to develop a viable, responsive, and focused inspection plan for the Joint command. The Joint IG must be an active and prominent member of the command and know the commander and the commander's philosophy and vision for the unit to best determine inspection topics. To stay abreast of current issues and trends within the command, the Joint IG should attend key staff meetings and major training events.
5. **Determining Inspection Topics.** Topics selected for an inspection must be focused on improving the command's readiness, warfighting, and mission capabilities. The Joint IG should review selected topics for their impact on unit readiness, value to the command, and priority to the commander. Below is a non-inclusive list of sources for developing inspection topics:

- Inspections required by law or regulation
- Subordinate-unit commanders suggested topics
- Joint Publications
- Universal Joint Task List (UJTL)

- Joint Mission Essential Task List (JMETL)
- The commander's direction
- COCOM and Joint Command Policy and Goals
- Joint Commander's Mission and Vision
- JCIG Databases
- Readiness Reports

The Joint IG should look for requirements and trends in problem areas from these sources requiring some immediate, or long-term, attention. Review of the COCOM's inspection priority list can also help to guide the development of a long-term inspection plan.

6. The Inspection Selection Process. The Inspection Selection Process has six basic steps:

a. Step 1: **Determine the Joint Commander's priorities.** The information a Joint IG needs to accomplish this step is located in paragraph five. The inspector may require a face-to-face meeting with the Joint commander if the priorities are not clear. Ultimately, the commander's priorities drive the inspection topics.

b. Step 2: **Analyze the information.** After reviewing the pertinent documents and information available within the command (in accordance with paragraph five), examine the inspection topics to ensure they focus on the unit's or command's readiness and are in line with the commander's priorities.

c. Step 3: **Make a prioritized list.** Based on information developed during the first two steps, draft a list of broad-based inspection topics and prioritize them with the Joint commander's priorities. The Joint commander will make the final determination on priority. Do not worry about narrowing the topics too much since they will be refined as part of the overall Inspection Process. Below is an example of a prioritized list that selects one inspection topic per quarter:

- (1) 1st Quarter, FY__: Individual Augmentation Requirements
- (2) 2nd Quarter, FY__: Information Assurance
- (3) 3rd Quarter, FY__: Force Protection
- (4) 4th Quarter, FY__: Radio Frequency Identification (RFID) Tag Usage

d. Step 4: **Gain the commander's approval.** Meet with the Joint commander to discuss the prioritized list. The commander may adjust the priorities or delete some topics and add others. Once approved, the inspection team can begin planning for the first topic.

e. Step 5: **Schedule the inspections.** Coordinate with the office responsible for maintaining the unit calendar ensuring inspection topics appear on the long-range calendar.

f. Step 6: **Notify the command.** Publish the inspection list and inspection schedule using a separate memorandum or include the inspection topics in the Joint Commander's Annual Training Guidance. Brief the inspection list and schedule as part of the Annual and Quarterly Training Briefing. Be sure to brief the types of units the Joint IG office intends to visit as part of each inspection so commanders can plan accordingly. Briefing the specific units is not required at this time.

Section 3.3

Inspection Approaches

1. **Purpose.** The purpose of this section is to discuss the two basic inspection approaches available to Joint Inspectors General.

2. **Two Inspection Approaches.** There are two basic ways to approach an inspection: as a structure or as a system. Both approaches are equally important, and one approach is no better than the other. However, one particular approach may be more appropriate based on the inspection. Both inspection approaches may be used for conducting compliance (standards/metric driven) and systemic inspections (faults in the system). For example, if a new unit is entering the COCOM area of responsibility (AOR), and the Joint commander wants to know the training and personnel readiness of the new unit, then the COCOM IG would use a compliance methodology and the standards that apply to that unit. If it is a Navy unit, then the COCOM IG will have to research the applicable Navy standards and develop information-gathering tools based upon those standards. If the commander wants to know how the system of Reception, Staging, Onward Movement, and Integration (RSOI) is working for incoming units, the systemic approach is more appropriate and would focus on Joint-level RSOI standards as found in JP 4-01.8.

a. **Structural Approach.** A structure is comprised of elements and sub-elements, like a battalion or a bicycle (see Figure 3-1), that relate to each other. A structural approach to an inspection will help a Joint IG determine how these elements relate to each other, where their boundaries rest, and where their responsibilities overlap. A compliance inspection is the most appropriate type of inspection when selecting the structural approach. For example, an inspection focusing on the overall health of an organization is considered a typical compliance inspection.

The Joint IG looks at the overall health of an organization by examining all staff functions. If one staff function is not working well, then the entire unit may suffer. If one part of the unit is not working properly, then the unit cannot accomplish its mission effectively. The Joint IG focus is to ensure that the structure functions well by looking at all aspects in general.

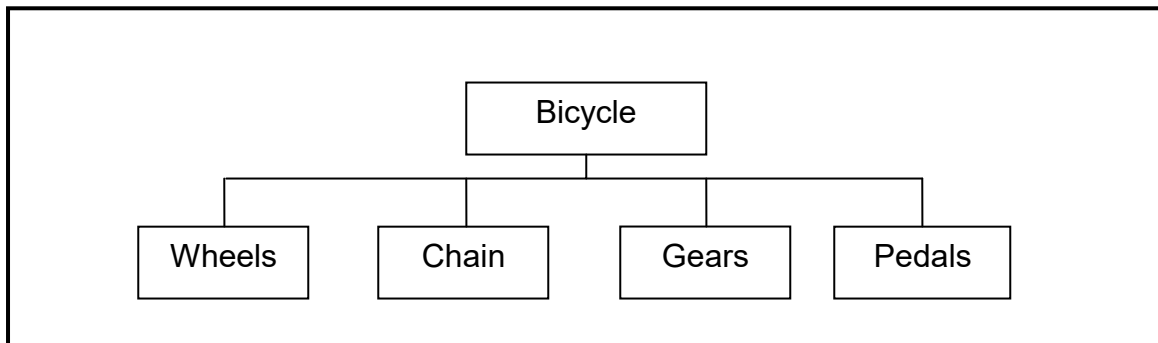

Figure 3-1
Structural Model

b. **Systems Approach.** A system is an activity that processes raw material (input) and transforms that material into something useful (output). That output may be goods or services or some other product. Systems tend to have self-correcting mechanisms (feedback) that help adjust the input or process based upon changing conditions or standards (see Figure 3-2). The overall system is comprised of sub-systems that interact to create the output. In this sense, functional areas relate to systems. For example, a Joint Command (system) takes input (people and things), processes them through sub-systems (functional areas such as personnel, training, logistics, and maintenance), and produces an output (a combat-ready unit). The sub-system of personnel management has several sub-sub-systems such as in- and out-processing, awards, pay, and records management. Each of these areas is a function and could be inspected in a functional inspection.

Based upon a systems approach, functional inspections tend to be narrow in focus and aimed at broader based issues that affect more than one unit or structure. Joint IGs may prefer this approach because the narrow scope allows them to take a systemic look at a topic, function, issue, or problem area and then determine the root cause(s) of the deficiencies. Fixing the system, or a particular sub-system, is the goal. See Figure 2-2 in Section 2.2 for a graphic representation of the major systems that support the Joint environment.

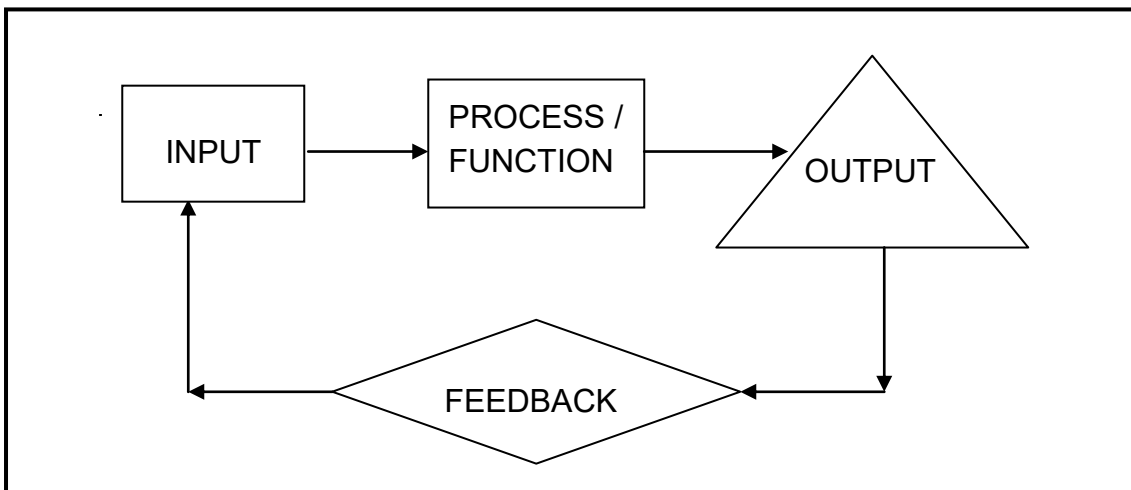

Figure 3-2
Systems Model

3. **Selecting an Approach.** A Joint IG can select one or both approaches to an inspection. Most inspections tend to follow one approach, but some inspections may require both approaches. The Structural Approach implies the Joint IG knows everything about the unit before conducting the inspection such as lines of command, responsibility, and their relationship to the each other. The Systems Approach implies the Joint IG not only understands the system but also what the correct output should be. Selecting the proper approach helps the Joint IG understand the scope of the inspection effort and defines boundaries in order to conduct the inspection successfully.

Section 3.4

Basic Elements of an Inspection

1. **Purpose.** This section discusses the five basic elements of an inspection.
2. **Five Elements of an Inspection.** One of the main purposes of an inspection is to provide leaders useful feedback to help them improve their command and subordinate commands/units. Joint IGs measure compliance against established standards ensuring the Joint command and its sub-units function effectively in their role. There are five inspection elements all Joint IGs must follow:
 - a. **Measure performance against a set standard.** Joint IGs should determine compliance against a standard. The Joint IG should prepare ways to determine why the unit or organization failed to meet the standard. By asking open ended questions, the unit personnel in question must respond with a more detailed answer. As a result, said personnel cannot get by with a yes or no answer. Likewise, you are one step further towards finding out the root cause(s) behind the non-compliance. Avoid the strict use of checklists! If a checklist is utilized, use follow-on questions that drill down toward the problem. A checklist will not help an inspector determine the root cause(s). Ask the following five questions:
 - 1) What do you do?
 - 2) How do you do it?
 - 3) How are you doing it?
 - 4) How do you know?
 - 5) What are your challenges?
 - b. **Determine the magnitude.** Focus on the major issues affecting the unit or organization's war fighting capability, readiness, health, and function of the organization. Do not take on trivial issues.
 - c. **Seek the Root Cause of problems found.** Use the Root Cause Analysis Model discussed in Section 3.4 to determine why non-compliance exists. Seeking the root cause applies to all inspections and not simply inspections conducted by Joint IGs. The Joint commander will want to know the root cause(s) in order to focus resources properly.
 - d. **Determine solutions and recommendations.** Examine the root cause(s) discovered and use them to craft an effective and meaningful solution(s) to the problem. Focus recommendations on achieving long-term, far-reaching solutions to the problems.
 - e. **Assign responsibility to the appropriate individuals or agencies.** The Joint commander shall receive a copy of the inspection report that includes findings, recommendations, and individuals or agencies required to resolve the issue(s). The Joint IG must coordinate findings and recommendations with these persons or agencies before finalizing the report with the Joint commander. Recommendations only have meaning and effect if the commander charges the right people with their implementation.

Section 3.5

Root Cause Analysis Model

1. **Purpose.** This section discusses and describes the Root Cause Analysis Model.
2. **Root Cause.** The root cause is the underlying reason why something does or does not happen. The Joint Inspector General (Joint IG) can apply the Root Cause Analysis Model to any inspection category in the interest of determining why there is or is not compliance with a set standard. Joint IGs should use the model not just to seek reasons for non-compliance but also to determine why something is going well. When an operation is working well, it is considered a best practice, and Joint IGs should share it with other commands and units.
3. **Two Forms of Root Causes.** The Joint IG will normally encounter two basic forms of root causes: Systemic Root Causes and Local Root Causes.
 - a. **Systemic Root Causes.** When a problem is widespread and presents a pattern, the problem is likely to be systemic in nature. A Joint IG can often trace a systemic problem back to a regulation, policy, or standard that is confusing, overly ambitious, or in conflict with another standard. Proponents of these regulations, policies, or standards should be required to fix the problem. Joint IGs normally seek root causes when conducting systemic inspections.
 - b. **Local Root Causes.** When a problem is not widespread and does not present a pattern, the problem is likely to be local in nature. Local problems affect only one unit or a small group of individuals. The solution to the problem usually rests within the unit or group. In some cases, solutions may rest within a higher echelon command. Local root causes are often associated with a particular person's decisions, demeanor, or statements.
4. **Root Cause Analysis Model.** The Root Cause Analysis Model represents an intellectual guide that helps an inspector think through all of the reasons why something is happening or not happening. The model structures an analytical process for the inspector to determine what went right or wrong by posing a series of questions in a particular form and sequence. The model appears on the next page at Figure 3-3.

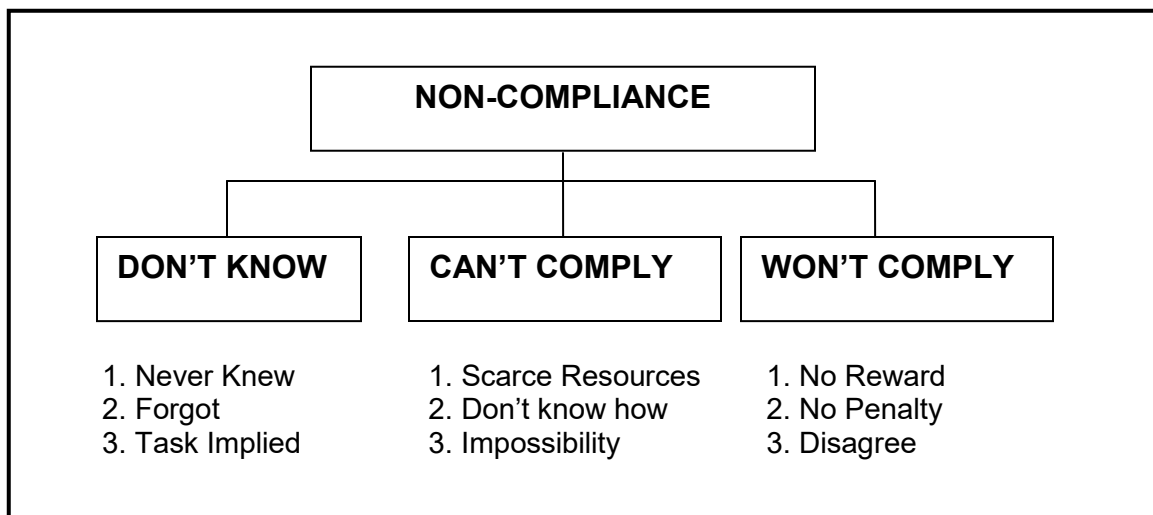

**Figure 3-3
Root Cause Analysis Model**

5. **Using the Model.** The Root Cause Analysis Model has three major headings: Don't Know, Can't Comply, and Won't Comply. Each heading includes three categories that the inspector can pose as questions. The Joint IG should start with the Don't Know heading then ask questions one through three (below) in sequence. For example, under the heading "Don't Know", the Joint IG should ask, "Did the person or unit ever know about the requirement?" The information gathered from interviews, sensing sessions/ focus groups, observation, and document reviews should lead the Joint IG to a more definitive answer. The Joint IG should **not** stop upon finding an answer to just one question. More than one reason may exist for compliance or non-compliance, hence the Joint IG should follow the model all the way through.

a. **Don't Know.**

(1) **Never Knew.** Did the person or unit ever know about the requirement?

A negative answer to this question usually means some organization at some echelon failed to get the information down to the required level.

(2) **Forgot.** Did the person or unit forget about the requirement? A

positive answer to this question usually suggests a local -- or personal -- problem and not a systemic problem.

(3) **Task Implied.** Was the task implied but the unit or person lacked the knowledge or experience to recognize the requirement? In organizations with rapid turnover and varying levels of experience, the leadership should compensate by providing more explicit guidance.

b. Can't Comply.

(1) **Scarce Resources.** Did the person or unit have the resources to accomplish the requirement? Many units often lack the resources (time, money, and personnel) to accomplish many of their assigned missions. Part of the problem may be a conscious decision a leader made concerning priorities. The Joint IG must consider the big picture before challenging a unit's priorities. However, the Joint IG has the authority to challenge the unit leader's priorities, even if they have been deemed to be the correct course of action at the time in question.

(2) **Don't Know How.** Did the person or unit know how to meet the requirement? A negative response to this question may suggest a lack of training or experience. The resources may be available, but the unit or person simply lacked the knowledge to perform the task -- even if the unit or person knew about the requirement.

(3) **Impossibility.** Was the requirement impossible for the unit or person to perform? A positive response to this question suggests that training, resources, and knowledge of the requirement were there, but the unit or person found the task impossible to accomplish. A number of potential reasons may surface. The task may have been overly ambitious and incredibly difficult to perform under any circumstances.

c. Won't Comply.

(1) **No reward.** Would the person or unit be rewarded for completing the requirement? Some people consciously decide not to comply with requirements that do not benefit them or their unit or simply avoid difficult tasks. A disciplinary penalty may be involved in decisions of this nature. Likewise, a person may simply avoid difficult tasks.

(2) **No Penalty.** Would the person or unit suffer a penalty by failing to complete the requirement? Some units or individuals choose not to comply with what they deem to be "obnoxious" tasks because no one will punish them for their non-compliance. Some people focus only on what keeps them out of trouble. A disciplinary penalty may be involved in a decision of this nature.

(3) **Disagree.** Did the person or unit disagree with the requirement? In some rare instances, individuals refuse to comply with a requirement they think is "dumb" or "stupid." Even if the task may seem mundane, this does not give the unit or person permission to neglect its existence. A disciplinary penalty may be involved.

6. **Root Cause Analysis Model Flow Chart.** The flow chart shown below in Figure 3-4 offers a visual representation of the root cause thought process.

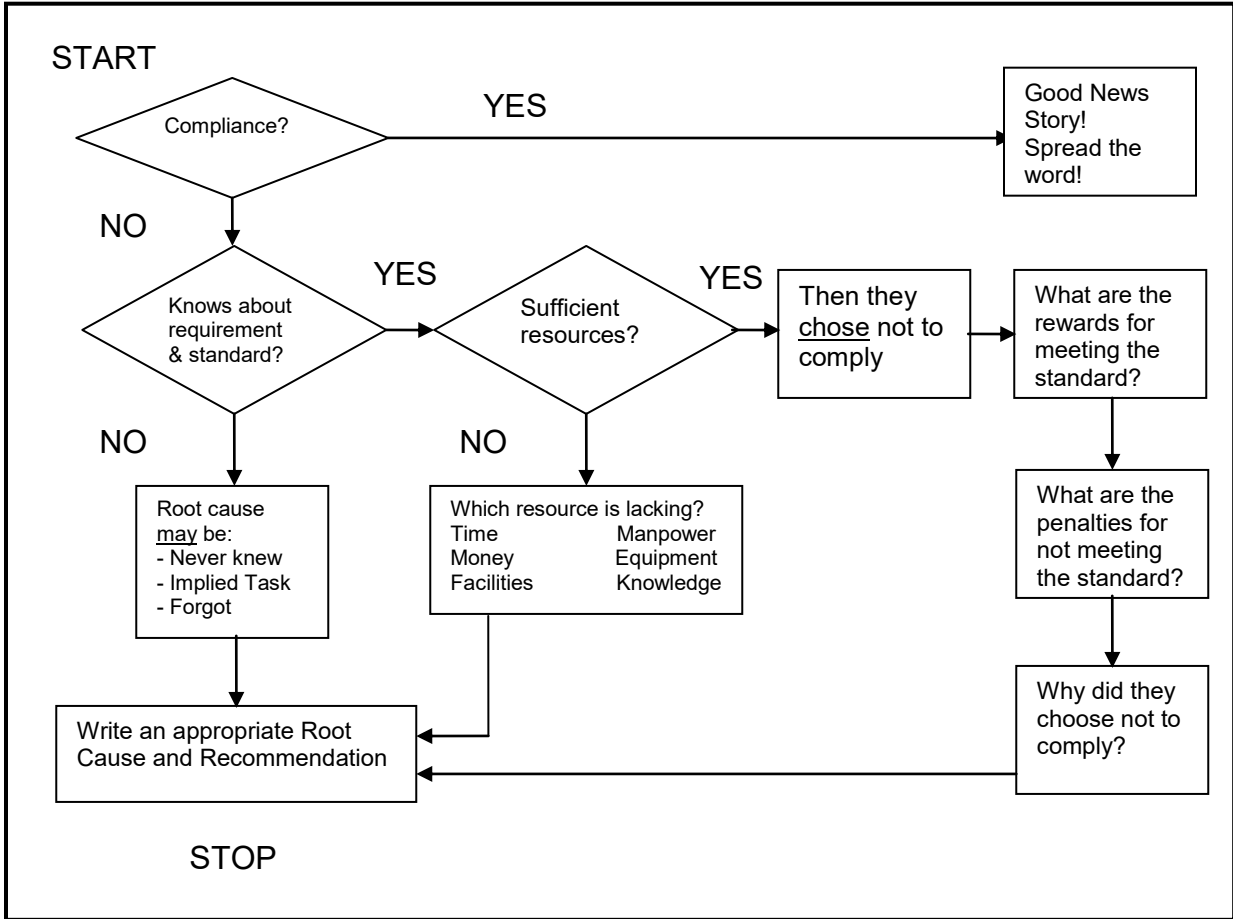

Figure 3-4
Root Cause Analysis Model Flow Chart

7. **Five-Why Analysis.** If Joint IGs are making any assumptions while employing the Root Cause Analysis Model, further analysis or verification may be necessary to strengthen the model's conclusions. The *five-why analysis* is an extension of the Root Cause Analysis Model. This technique allows the Joint IG to dig deeper and confirm that one or more of the root-cause reasons of Don't Know, Can't Comply, or Won't Comply caused the problem by asking the question "Why?" five times. There is nothing magical about the number five; it is only a guide. Sometimes the IG team will find the root cause by asking a question only two or three times, or it may take six, seven, or more iterations.

a. The five-why analysis process is composed of three steps:

Step 1. Begin with a problem statement. The IG considers the problem in a simple and brief way without assigning blame or assuming the answer. If the issue is complex, be sure to define the scope of the problem, i.e., what is included and what is not. A good problem statement may be "RFID (Radio Frequency Identification) tags are not being used as prescribed."

Step 2. Ask "why?" until you find the answer. The IG begins by asking "why?" to the problem statement. Then, while staying focused on the original problem statement, the IG asks "why?" to each subsequent response (or cause). If there are multiple causes suggested by the inspected units, develop each branch and sequel until you identify the root cause.

Step 3. Identify the root-cause category. The IG labels the root cause(s) as one of the three corresponding categories under the Root Cause Analysis Model – Don't Know, Can't Comply, or Won't Comply. The IG should then compare the results of the five-why process to the original Root Cause Analysis Model results to ensure the identified root cause was not just a symptom of the problem. Using the mock problem listed in Step 1, the following diagram (Figure 3-5) illustrates a simple example of the five-why analysis:

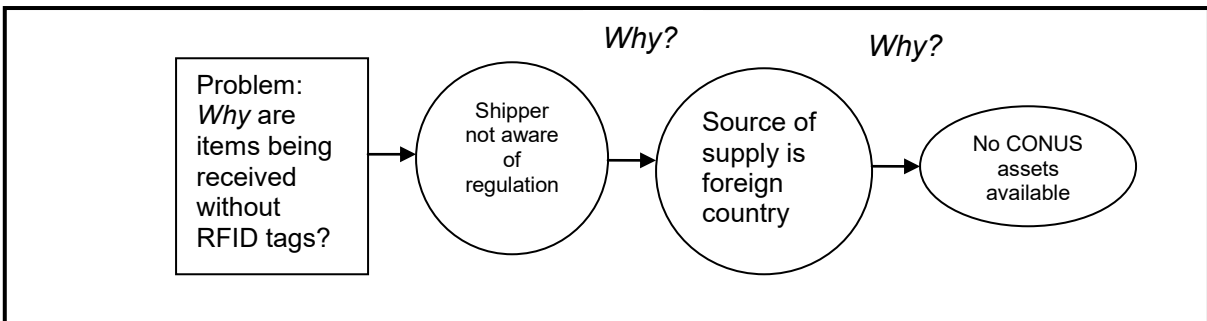

Figure 3-5
Simple Example of Five-Why Analysis

b. When the problem is more complex, the inspection information may lead to multiple streams of responses (branches). Under Step 2, the IG fully develops each branch and sequel of responses to the "why?" questions. Under Step 3, the IGs associate the final response to *each* branch with an appropriate root-cause category. The IG then takes the additional step of distinguishing which of the causes represents the *primary* root cause of the central problem statement and which causes represent possible *symptoms* of the problem.

c. To aid in the identification of the primary root cause, ask the question, "If we fix this particular cause, will the other causes disappear?" In most cases, resolving a primary root cause eliminates or minimizes any of the other branches relating to the problem statement. Resolving the issue of foreign sources of supply being unaware of the RFID tag requirement would likely cause the "Won't comply" problem to fall away. However, more than one root cause may be applicable to a particular problem statement. For example, the IGs determined that "no CONUS (continental United States) assets available" was a root-cause factor for missing RFID tags. However, resolving this "Won't Comply" root cause will not necessarily resolve the lack of domestic source of supply issue. In such cases, the inspector may choose to identify more than one root cause for resolution in the IG inspection findings.

d. A team setting is the most effective way to conduct the five-why analysis. The best opportunities for applying this tool are during the *In-Process Reviews* and at the *Analyze the Results and Crosswalk* step of the Joint IG Inspections Process, which will be described in detail in Chapter 4 and subsequent chapters.

Note. Maximum participation of the Joint IG inspection team and associated subject-matter experts is essential to this analysis. Some responses proposed by the team may require further verification. Therefore, allocate sufficient time for additional team meetings if necessary.

Chapter 4

Inspections Process

1. **Purpose.** This section discusses the three phases of the Inspection Process.
2. **Inspections Process.** Inspection Process is a sequential planning and management tool allowing the Joint Inspector General (Joint IG) to plan and conduct inspections. The process was designed for Joint IGs; however, this process applies equally to inspections conducted by non-IGs in Joint commands.
3. **Three Phases of the Inspection Process.** The Inspections Process comprises a series of 17 diagnostic steps that fall within three separate phases. These phases are:
 - a. Phase One: **Preparation** Chapter 5
 - b. Phase Two: **Execution** Chapter 6
 - c. Phase Three: **Completion** Chapter 7

These phases include specific steps of the process the Joint IG can tailor to suit his or her needs. The process is an extremely effective way of planning for an inspection that is narrow in focus and requires a great deal of research. The Joint IG should resist the temptation to combine or skip steps in an effort to reduce time spent. These steps are aligned in a logical order to produce necessary products for completing follow-on steps. The Joint IG should consider this process when planning and conducting IG inspections.

4. **Joint IG Inspections Process Chart.** Figure 4-1 is a graphic portrayal of the Joint IG Inspections Process and captures all 17 steps:

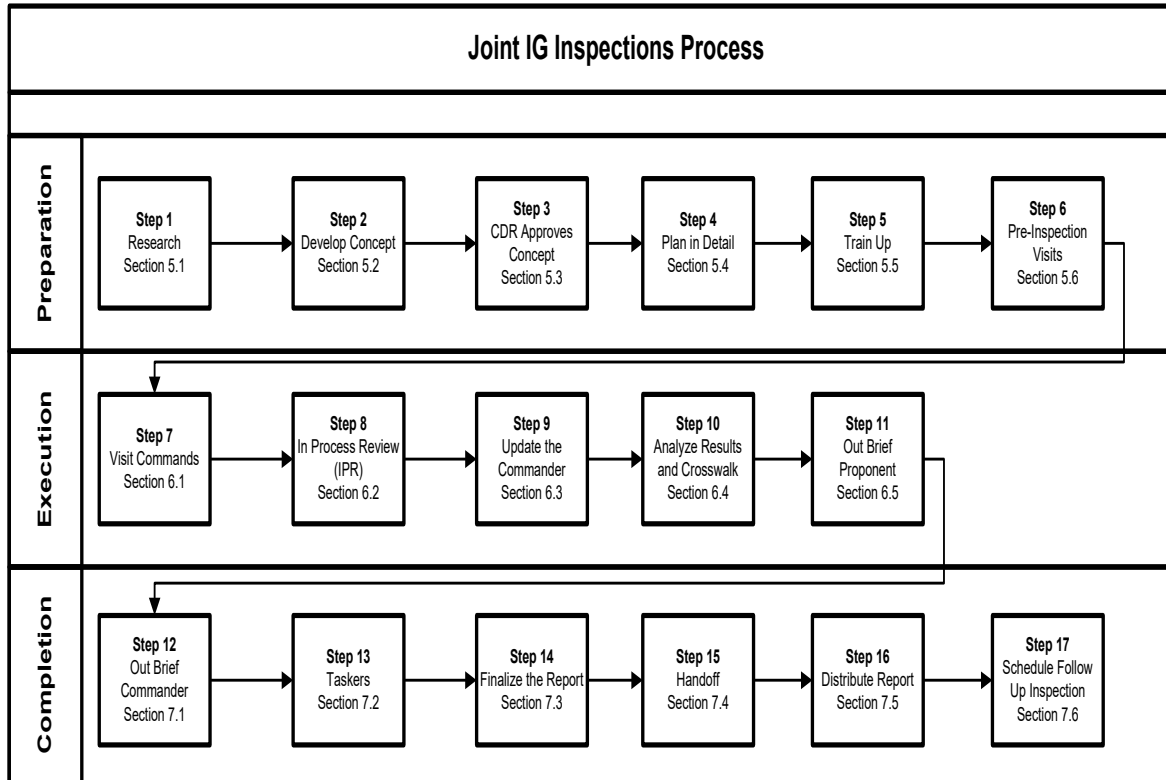

Figure 4-1
The Joint IG Inspections Process

The following chapters will walk through each phase: Chapter 5 discusses the “preparation” phase, Chapter 6 breaks down the “execution” phase, and Chapter 7 dissects the “completion” phase.

Chapter 5

Preparation Phase

- Section 5.1 Step 1 Research
- Section 5.2 Step 2 Develop Concept
- Section 5.3 Step 3 Commander Approves the Concept
- Section 5.4 Step 4 Plan in Detail
- Section 5.5 Step 5 Train up
- Section 5.6 Step 6 Pre-inspection Visit

Chapter 5

Preparation Phase

1. **Purpose.** This section discusses the six steps in the Preparation Phase of the Inspections Process.
2. **Preparation Phase.** Preparation Phase is the most important part of the inspection process because it establishes the inspection plan. The inspection plan is what the inspection team will follow to gather information and conduct the inspection. If an inspection team does not follow the six steps involved in this phase, then the inspection will almost certainly run into difficulty during the Execution Phase. Below are the six steps of this phase. Figure 5-1 is a flow chart depicting the preparation phase.
 - a. Research
 - b. Develop the Concept
 - c. Commander Approves the Concept
 - d. Plan in Detail
 - e. Train Up
 - f. Pre-Inspection Visits

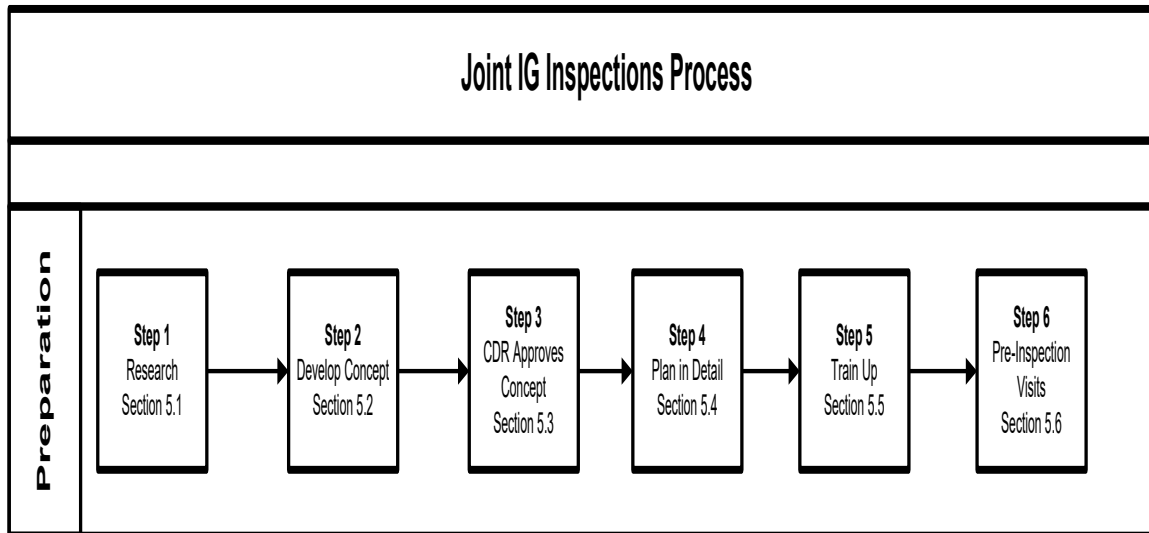

Figure 5-1
Preparation Phase

Section 5.1

Preparation Phase Step 1. Research

1. **Research Step.** The Research Step of the Preparation Phase is the first and most important step a Joint IG must take when trying to learn about the inspected topic. Most Joint IG inspections will be systemic inspections that are narrow in scope and focused on a particular issue or functional area. The Joint IG approaches these problems with the intent to identify and then fix systemic problems within a system or functional area. The entire inspection team participates in the research step. Some topics require each team member to tackle a certain aspect and then share what they have learned with the team members. These topics tend to require specialized training and subject-matter expertise that the average Joint IG may lack. Therefore, the Joint IG must delve into the subject matter through a variety of means and become a subject-matter expert on certain aspects of the topic. Ultimately, this step will generate two very important products for the inspection team:

a. **Inspection Purpose.** Inspection Purpose is a clear statement of the inspection's overarching goal.

b. **Inspection Objectives.** The objectives are the most important features of the inspection because they focus the inspection effort and drive the information-gathering portion of the inspection. Objectives are inspection focal points that support the overarching goal of the inspection. Objectives should be measurable and based on established criteria.

2. **Conducting Research.** There is a systematic approach to conducting research within Joint IG offices. This approach ensures that Joint IG inspections are meaningful and truly focused on the most important issues. In addition, our researchers strive to ensure that all research is relevant to the commander and his affiliates. The seven steps to conducting focused research are:

a. **Review Guidance.** Research of an inspection topic should always begin with the commander's guidance, which will identify specific areas of a process or function of most interest to the commander. Understanding the commander's guidance will potentially save the inspection team hours or days of unnecessary work. The commander's guidance translates directly into the focal points of the inspection, which may become the Inspection Objectives. Even if the commander provides no specific guidance on an inspection topic, the Joint IG can derive a substantial amount of intent from existing knowledge of the commander's priorities and existing situational awareness of current operations and planning. For this reason, the Joint IG must play an active role with their organization.

b. Review Existing Literature. This review involves an examination of relevant articles, lessons learned, and after-action reports, facilitating greater understanding of the program or activity the Joint IG is inspecting. Research should identify and study past inspection reports or results (published inside or outside the organization) relevant to the inspection. Existing inspection materials may be helpful in deriving potential objectives, standards, and systemic trends relating to the topic. However, there cannot be any guarantees on the validity or reliability of data gathered. Use technical channels to consult with the COCOM IG or other Joint IGs in the field for existing inspection reports related to the current topic. It is important to review your database for any trends or other inspection reports regarding your topic.

c. Explore Publications for Standards. Search and review all DoD and Joint regulations, doctrinal manuals, policies, and operations orders associated with the topic. Most Joint standards are delineated in the Joint Publications (JP 1-0 through JP 6-0) described in Section 2.1. This effort will help determine "what right should look like" and will provide some, but not all, of the applicable standards for the inspection. Web-based internet research is a practical and expedient way to locate the most current policies and doctrine. Many on-line publications have hyper-links to other referenced publications, allowing the researcher to search quickly and gather related materials.

d. Consult Subject-Matter Experts. Discuss the topic with subject-matter experts (SME) inside and outside the organization for clarification and to fill any remaining knowledge gaps. When possible, face-to-face meetings with local proponents can help clarify standards that apply to the topic and describe the doctrinal applications of the policies. Their experience and expertise will help you understand the various support activities, resources, requirements, and constraints affecting the activity or process the Joint IG team is inspecting. The topic may require the Joint IG to involve multiple proponents and SMEs to get a complete and accurate picture.

e. Topic Analysis by Team Members. The Joint IG should analyze the topic carefully to ensure understanding of all aspects as it pertains to the inspected program or activity. The old adage "stick to what you know" does not apply to Joint IG inspectors who, in most cases, must dramatically expand their knowledge base on a subject to ensure an inspection is relevant and responsive to the needs of the command.

Two methods for analysis can be useful in helping the Joint IG team "dissect the anatomy" of a program, system, or function they plan to inspect and gain a better understanding of the requirements, components, resources, activities and relationships involved. The first method involves "function modeling" by graphically breaking down a system into its basic functions and the requirements or activities needed to perform each of those functions. The second method of analysis is a "DOTMLPF" approach, or examination of Doctrine-Organization-Training-Material-Leadership/Education-Personnel-Facilities requirements involved in an activity or program.

(1) **Function Modeling**. Function modeling graphically depicts the decisions, actions, and activities of a process, function, or system in order to describe and understand its functional aspects. Mapping these functions and the elements required to perform them allows the Joint IG to "see" the complete picture of the inspection topic and the areas that may be "clogging up" (the focus of the inspection objectives). Directly involving the proponents and SMEs with whom you have consulted in earlier research will greatly benefit this analysis. This process begins as a

brainstorming session; use a dry-erase board or chalkboard to capture the information. The Joint IG team starts grouping together activities that are closely related or functionally similar using information derived from the literature review, publications review, and SME interviews. Through the grouping process, you will see a logical flow and hierarchy of functions within the process. Your team can illustrate the relationships and hierarchy of these functions by creating flow charts. The graphic below (Figure 5-2) illustrates the flow of activities where the result (output) from one function can lead to the performance of other functions or series of functions.

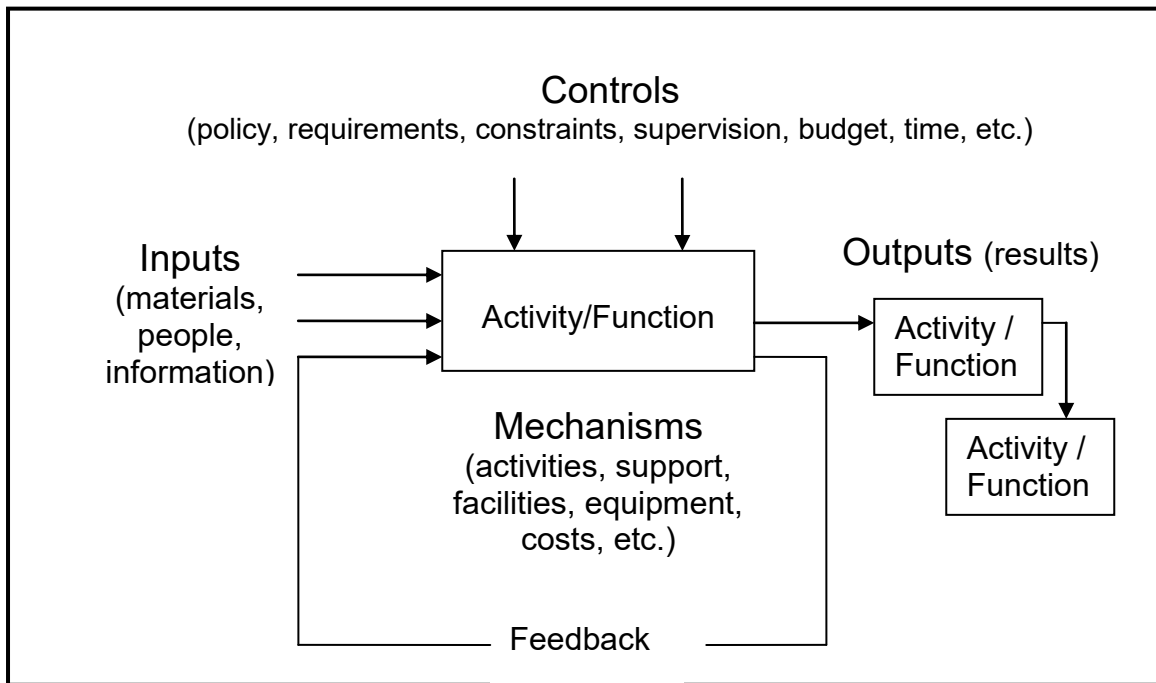

**Figure 5-2
Function Modeling**

Within the flow chart, the Joint IG can analyze the context of any function or activity and isolate and examine any one of these functions to greater levels of detail as needed. As depicted in Figure 5-2, a "box-and-arrow" technique using the "ICOM" method (Inputs, Controls, Outputs, and Mechanisms) is the most common way to analyze particular functions of interest to the command and shows their relationships to the activity. The ICOM is the working element of function modeling.

- **Inputs** – Elements transformed by the activity or process. Inputs normally include material, people, or information.
- **Controls** – Those elements related to the activity that constrain or govern how to conduct the activity. Examples include policy, law, time constraints, budget constraints, doctrinal requirements, standing operating procedures, and guidance.
- **Outputs** – The results of the activity. Outputs can be things produced by the activity or inputs transformed by the activity. Outputs also include feedback information to refine the activity.

- **Mechanisms** – Those things that perform or support the activity.

Mechanisms may be people, systems, facilities, or equipment necessary to accomplish the activity.

(2) **Doctrine, organization, training, material, leadership/education, personnel, and facilities (DOTMLPF) Analysis.** Much like the bicycle requires several different support systems (frame, wheels, pedals, chain, sprockets, etc.) working together to perform its function, military activities and operations require various support systems to keep them working effectively. The Joint IG can analyze the support systems of any inspection topic by addressing the categories of DOTMLPF. The Joint IG can also apply the DOTMLPF analysis to gain a holistic understanding of the inspection topic. The DOTMLPF approach is particularly useful in determining key aspects of the inspection subject focusing toward the inspection objectives. An analysis session is pure brainstorming among the Joint IG team to associate the requirements identified during the preliminary research by DOTMLPF categories and to develop some potential objectives for further consideration. The Joint IG should not attempt to conduct the DOTMLPF analysis without consulting the SME/proponents related to the inspection topic.

f. Develop Inspection Purpose. With sufficient guidance and research at this point, the Joint IG inspection team should be ready to propose the goal or inspection purpose. The Inspection Purpose is a clear and concise statement of the inspection team's goal for the inspection. Consider the following example:

Inspection Purpose. The purpose of this inspection is to determine why JTFs X-Ray, Yankee, and Zulu are consistently undermanned with regard to Individual Augmentation (IA) personnel.

This example narrows the focus of the inspection by stating that the inspection team's efforts will focus on determining if IA personnel sourcing is effective. The goal is to get at any systemic issues concerning IA personnel assignments.

g. Develop Inspection Objectives. The Joint IG team should start developing objectives based on command guidance and to identify important concerns or issues for the objectives. Consider using the function modeling and DOTMLPF to identify high-impact requirements and activities for developing objectives. Develop as many objectives as necessary to accomplish the intent of the inspection as outlined by the commander. As a general rule, the team should develop no more than five (5) objectives per inspection. Five objectives are sufficiently manageable for a team to break down into quantifiable Sub-Tasks.

An Inspection Objective should be clear, concise, and capture the essence of what the team needs to learn. Use active verbs to explain what the team wants to capture. The objectives can be broad in nature or focus on a specific issue where only one standard applies. Here are two examples:

- 1) Determine if there is a gap in the IA personnel sourcing system

This objective will require a more subjective approach to the topic and not simply the results of the inspection team's personal observations. The opinions of leaders and personnel officers will certainly matter in terms of measuring the effectiveness in both

their minds and the minds of the inspection team's members. This evaluation approach relies more on analytical thought and less on following a prescribed performance measure or standard. Objectives phrased in this manner suggest that several standards (regulations, policies, etc.) apply to this objective.

2) Determine if Joint Force Manpower and Personnel Planning is being conducted in accordance with Joint Publication 1-0, Personnel Support to Joint Operations.

This objective is very narrow in scope and focuses clearly on compliance with a specific standard. In other words, only one standard applies to this specific objective. The inspection team members can answer this objective through observation and by reviewing logs, records, or other documents; the team does not necessarily require direct input from unit leaders to determine if the unit is in compliance with this objective.

These two types of inspection objectives can complement each other and comprise some or all of the objectives developed for inspecting a particular topic. Two of the objectives may identify specific standards (regulations, policies, operational plan (OPLAN), etc.) while the other three objectives may focus on assessing issues in a more analytical or subjective manner. The important thing to know before developing each objective is whether or not some standard or even a doctrinal application exists for the objective.

3. Approving the Inspection Purpose and Objectives. The purpose and objectives will form the basis for developing the concept of the inspection as part of Step 2 of the Inspections Process. Therefore, the team must agree upon the purpose and objectives appointed.

Section 5.2

Preparation Phase

Step 2. Develop the Concept

1. **Develop the Concept.** The inspection concept is dependent upon development of the inspection purpose and objectives from Step 1 – accomplished by completing effective and in-depth research on the inspection topic. The concept is nothing more than a plan outlining, in general, how the inspection team plans to accomplish the inspection. The physical output of this step is the Concept Letter, which the inspection team develops to communicate formally the major parts of the inspection concept. This letter will later form the basis for the Concept-Approval Briefing to the commander. If a letter or memorandum is not required for staffing or any other purpose as determined by the commander, then the inspection team may convert the concept directly into a briefing format.

2. **Inspection Concept Letter.** The purpose of the Inspection Concept Letter (sometimes called a Statement of Work) is to summarize the inspection concept in a two or three-page memorandum to gain approval of the command IG or other staff members as required. The Inspection Concept Letter includes the following items:

- a. **Purpose** - developed during the research step.
- b. **Objectives** - developed during the research step.
- c. **Scope** - describes the team's intended task, organization and the number of units or installations the team plans to visit.
- d. **Focus** - mentions whether the inspection is a compliance or systemic inspection and describes the basic intent of the inspection as viewed by the inspection team.
- e. **Timeline** - outlines the key milestone dates from the time the commander signs the Inspection Directive to the completion of the Final Report.
- f. **Timing of Feedback** - discusses the nature of the feedback that each inspected unit or location will receive from the team and may include a comment about when the commander can expect a mid-inspection update if necessary.
- g. **Notification** - explains how the inspection team plans to notify the inspected units.

3. **Sample Inspection Concept Letter:** A sample Inspection Concept Letter appears on the next page.

COMMAND LETTERHEAD – Sample Inspection Concept Letter

20 AUG ____

MEMORANDUM FOR THE COMBATANT COMMANDER

SUBJECT: Inspection Concept for Individual Augmentation (IA) Sourcing Process

1. PURPOSE: The purpose of this inspection is to determine why JTFs X-ray, Yankee, and Zulu are consistently undermanned with regard to IA personnel.

2. OBJECTIVES:

- a. Determine if there is a gap in the IA personnel sourcing system.
- b. Determine if J-1 and J-3 personnel are properly trained.
- c. Determine the readiness and workload impact due to the undermanning of IA billets.

3. SCOPE: One team of three inspectors will visit and interview all three JTF J-1/J-3 personnel and conduct sensing sessions / focus groups with officers and enlisted leaders.

4. FOCUS: This inspection will be a systemic inspection that focuses on the IA sourcing process and the impact to mission readiness based on undermanning funded IA billets in each JTF.

5. TIMING OF FEEDBACK: The Chief, Inspections Branch, will conduct a mid-inspection briefing with the Combatant Commander followed by a final-report briefing at the conclusion of the inspection. During the conduct of the inspection, each team will provide the inspected unit with immediate but general feedback following the visit in the form of an out-briefing. This out-briefing will capture the salient points of the team's preliminary findings and articulate in detail those results that may require immediate action.

6. TIMELINE:

- a. Gain Joint Commander's approval of the concept: 24 August
- b. Send Notification Letter: 20 September
- c. Send Detailed Inspection Plan to Units: 20 October
- d. Visit first unit or staff section: 20 November
- e. Visit last unit or staff section: 04 December
- f. Final results to the Commander: 30 December
- g. Final written report complete: 10 January

7. NOTIFICATION: The Inspection Team will announce the inspection in advance using a Notification Letter and work with each unit, command, or staff agency to develop detailed inspection schedules and gather resources.

//original signed//
I. M. Army
MAJ, IG
Chief, Inspections Branch

Section 5.3

Preparation Phase

Step 3. Commander Approves the Concept

- 1. Develop the Concept-Approval Briefing.** The Concept-Approval Briefing is a decision briefing the inspection team presents to the Joint commander to gain his or her approval of the inspection concept. The briefing format closely follows the respective paragraphs of the Concept Letter and offers no additional information. At the conclusion of the briefing, the inspection team requests the commander's approval. If the commander approves the concept, then the inspection team will present the Joint commander with an Inspection Directive for signature. The only physical output of this step is the Inspection Directive.
- 2. Sample Concept-Approval Briefing.** A sample Concept-Approval Briefing based upon the Concept Letter is located below.



Decision Briefing Inspector General

Inspection Concept for Individual
Augmentation Sourcing Process
20 November to 10 December

Purpose

- To gain the Commander's approval of the inspection concept for evaluating the IA Sourcing Process for all Joint Task Forces within our AOR.
-

Agenda

- Inspection Purpose
 - Objectives
 - Scope
 - Focus
 - Timing of Feedback
 - Timeline
 - Notification
-

Inspection Purpose

- The purpose of this inspection is to determine why JTFs X-ray, Yankee, and Zulu are consistently undermanned with regard to IA personnel.
-

Inspection Objectives

- Determine if there is a gap in the IA personnel sourcing system.
 - Determine if J-1 and J-3 personnel are properly trained.
 - Determine the readiness and workload impact due to the undermanning of IA billets.
-

Scope

- One team of three inspectors will visit and interview all three JTF J-1/J-3 personnel and conduct sensing sessions/focus groups with the officers and enlisted leaders.
-

Focus

- This inspection will be a systemic inspection that focuses on the IA sourcing process and the impact to mission readiness based on undermanning funded IA billets in each JTF.
-

Timing of Feedback

- The Chief, Inspections Branch, will conduct a mid-inspection briefing with the Combatant Commander followed by a final report briefing at the conclusion of the inspection.
 - During the conduct of the inspection, each team will provide the inspected unit with immediate – but general – feedback in the form of an outbrief.
-

Timeline

Send the Notification Letter	20 September
Send the Detailed Inspection Plan to the Units	20 October
Visit First Unit or Staff Section	20 November
Visit Last Unit or Staff Section	10 December
Final Results to the Commander	30 December
Final Written Report Complete	10 January

Approval

- Do you approve of this inspection concept?
- If yes, please sign the Inspection Directive.
- Do you have any additional guidance for the inspection?

3. **Inspection Directive.** Inspection Directive is a critical document that authorizes the Joint IG to conduct the inspection and gives the Joint IG temporary tasking authority for the purposes of the inspection. The commander's signature at the bottom of this document means the Joint IG is acting under the specific direction of the commander. The inspection team must craft the Inspection Directive carefully to ensure the language within the document authorizes the inspection team to gain access to the areas required and to task those units or agencies within the command to support or participate in the inspection. The Inspection Directive should include the following:

- a. A statement directing the Joint Inspector General to conduct the inspection.
- b. A list of all objectives that pertain to the inspection.
- c. A statement that outlines the tasking authority for all organizations assigned to the command.
- d. A statement that authorizes the IG to have access to all activities, organizations, and information sources required to conduct the inspection.

A sample Inspection Directive appears on the next page.

COMMAND LETTERHEAD – Sample Inspection Directive

24 August ____

MEMORANDUM FOR THE COMBATANT COMMAND INSPECTOR GENERAL

SUBJECT: Directive for Assessment (Individual Augmentation Sourcing Process)

1. You are directed to evaluate the effectiveness of the Individual Augmentation (IA) Sourcing Process in the Joint Task Force Area of Responsibility, specifically JTF-X, JTF-Y, and JTF-Z.
2. The assessment will focus on the following objectives:
 - a. Determine if there is a gap in the IA personnel sourcing system.
 - b. Determine if J-1 personnel are properly trained.
 - c. Determine the readiness and workload impact due to the undermanning of IA billets.
3. You are authorized to task all JTF staff and subordinate headquarters for those resources required to ensure the successful accomplishment of this assessment.
4. You are authorized unlimited access to JTF activities, organizations, and all information sources necessary to complete this effort.
5. You will provide me with a mid-course progress review on or about 30 November followed by a written report not later than 10 January.

I. Know
ADM, USN
Commander

Section 5.4

Preparation Phase Step 4. Plan in Detail

1. **Planning in Detail.** This step is the most comprehensive and critical step of the entire Preparation Phase. The products developed by the inspection team during this step will ensure the smooth and effective execution of the inspection for the remaining two phases. The four physical outputs of this step are as follows:

- a. Sub-Tasks for each Inspection Objective
- b. Methodology
- c. Notification Letter
- d. Detailed Inspection Plan

2. **Developing Sub-Tasks.** Sub-Tasks focus the inspection team on specific ways to seek information and then answer the basic requirement of an Inspection Objective. Sub-Tasks are the mechanisms that drive the gathering of information during the inspection. The inspection team breaks down each Inspection Objective into achievable tasks based upon the standards and doctrine governing the inspection topic and the Joint IG's methods for gathering information. Joint IG inspectors have five information-gathering techniques or domains available to them. Those domains are as follows:

- a. **Interviews** with key leaders or personnel.
- b. **Sensing sessions** with enlisted personnel, officers, and civilians (as required).
- c. **Reviews** of pertinent documents such as Joint Publications, Joint Task Lists, Joint Regulations, Standard Operating Procedures (SOPs), JTF policy letters, training-guidance memoranda, etc.
- d. **Observation** of major training events, live-fire exercises, after-action reviews, inspections, morale, etc.
- e. **Surveys and Questionnaires** for all interview or sensing session populations (normally used for topics that require some basic factual information or a sampling of a unit's population; DoD Instruction 1100.13, Surveys of DoD Personnel, applies).

These information-gathering methods will guide the development of each Sub-Task so the Joint IG will not develop a task the inspection team cannot accomplish using the available techniques. Gathering information to answer a particular Sub-Task is not limited to one information-gathering technique. Two or more information-gathering techniques may be applicable to a Sub-Task.

Developing Sub-Tasks requires a great deal of thought and relies largely upon information gleaned from the Research step (Step 1) of the Preparation Phase. Subject-matter experts and the applicable standards, policies, and regulations are the best sources of information when developing Sub-Tasks. Each Sub-Task must have a clearly stated or implied purpose that directly supports the information requirements of the objective for which the Sub-Task applies. Some examples of Sub-Tasks for an IA Manning inspection are as follows:

Objective 1. Determine if there is a gap in the IA personnel sourcing system.

Sub-Task 1.1. *Interview* JTF J-1 and J-3 staff to determine if they understand the policy requirements of the IA sourcing process.

Sub-Task 1.2. *Conduct sensing sessions* with JTF J-1 and J-3 personnel to determine any gaps in the IA sourcing process from the CJCS level to the JTF.

Objective 2. Determine if JTF J-1 and J-3 personnel are properly trained.

Sub-Task 2.1. *Interview* JTF J-1 and J-3 personnel to determine training and experience with regard to Joint manpower management.

Objective 3. Determine readiness and workload impact due to under manning of IA billets.

Sub-Task 3.1. *Conduct sensing sessions* to determine the impact on readiness with regard to undermanning of funded IA billets.

Sub-Task 3.2. *Review* mission readiness data in each JTF as it pertains to personnel and mission accomplishment.

Each example listed above is tied directly to one information-gathering activity (or domain), sometimes this can limit the perspective and scope of the information gathered for that particular Sub-Task. Using multiple information-gathering domains to answer a Sub-Task is best due to the variety of sources and perspectives leading to a more informed finding statement. One can signal this broader information-gathering perspective by simply re-phrasing the Sub-Task to avoid limiting the information-gathering activities the Joint IG inspection team will use to answer that particular Sub-Task. For example, Sub-Task 1.1 can be re-phrased as follows:

Sub-Task 1.1. Determine if JTF J-1 and J-3 personnel fully understand the IA sourcing process (conduct interviews and sensing sessions).

The Joint IG inspection team must list in parentheses, for their own purposes, the information-gathering domains that apply to this broader Sub-Task. This information will not appear in the Final Inspection Report but will signal clearly to the Joint IG inspection team which information-gathering activities apply to the Sub-Task. This information becomes critical in the next step when the team uses the Sub-Tasks to develop a baseline methodology.

The completed Sub-Tasks will later form the basis for the findings the inspection team will generate during the Execution and Completion Phases of the Inspections

Process. The inspection team will develop at least one finding statement per Sub-Task. The sum of these findings statements for each Sub-Task will form the basis for the final response to each Inspection Objective. However, the Joint IG inspection team must remember that Sub-Tasks are a Joint IG tool the team can manipulate, refine, combine, or delete as necessary during the inspection process. The team should refrain from making these changes haphazardly since the Sub-Tasks are the mechanisms that drive the gathering of information during the inspection.

3. Developing a Methodology. A methodology is the inspection team's plan for physically conducting an inspection at a unit or within the Joint IG's area of responsibility. The Sub-Tasks the team developed for each objective will drive this approach since the team must develop a plan allowing them to conduct the information-gathering activities required for the inspection. This particular sub-step of Step 4 has three separate physical outputs:

a. Task Organization of the Inspection Team. The Inspection Team Leader must decide how he or she wants to organize the team for the inspection. If time is short but the sampling of units to inspect is high, the Team Leader should consider splitting the team into smaller teams each led by an Assistant Inspector General (AIG). Two or more inspection teams can inspect more units over a shorter period of time. Traveling as one team may be necessary for certain inspections. The team must also consider the type and number of augmentation personnel required. With the authority granted to the Joint IG in the Inspection Directive, the team can task the appropriate staff, agency, or office for subject-matter experts to serve as Temporary Assistant IGs (TAIG) and assist in the conduct of the inspection. These augmentees must be sworn in as a TAIG and be aware of Joint IG information restrictions (see The Joint IG Concept and System Guide, Chapter 2). The TAIG must also be aware of the Joint IG tenet of confidentiality and have specific responsibilities within the team (or teams). Normally, these augmentees are best suited to conduct reviews of key documents. A sample task organization for this team is as follows:

Team

CDR Sailor (AIG)

Maj Airman (AIG)

Maj Marine (TAIG, COCOM J-1 Staff)

CDR Sailor is the overall Team Leader for the entire inspection effort.

b. Baseline Methodology. The baseline methodology is the standard approach the inspection team (or teams) will follow during an inspection visit to a unit or agency. This approach is based upon the team's information-gathering requirements (as outlined in the Sub-Tasks) and assigns information-gathering responsibilities to each team member. Each team member must have a specific function within the team. The baseline methodology is the way the team would ideally like to conduct an inspection visit at a unit or agency without considering time restrictions. A sample baseline methodology for an inspection on the topic of IA Manning follows:

(1) Personnel to Interview (Interviews and Sensing Sessions):

- JTF J-1 and J-3 (**Maj Marine / CDR Sailor - Interviewers**)
- Officers O-4 and above (**Maj Airman / CDR Sailor - Sensing Session**)

- E-7 and above (**Maj Airman / CDR Sailor - Sensing Session**)

(2) Documents to Review in Advance (Document review conducted by TAIG from COCOM J-1):

- SOPs for IA Sourcing Process
- Joint Manning Documents for JTFs X, Y, and Z
- Current IA Sourcing Process procedures per JP-1, Appendix F
- Personnel Readiness reports
- Mission Readiness reports

(3) Events to Observe (as available based upon the day the inspection team visits the unit):

- Morale
- Working conditions

Note: All team members will observe training as available.

c. **Sample Inspection Itinerary.** The Sample Inspection Itinerary applies time constraints to the baseline methodology. The inspection team must decide how long the team will spend at a particular unit or agency (one day, two days, or even five days). After this decision, the team will develop a Sample Inspection Itinerary for each day spent at a unit or agency. This itinerary will allow the team members to see precisely what parts of the baseline methodology they can accomplish during the given time period and to set priorities accordingly. Conducting all of the interviews and sensing sessions outlined in the baseline methodology may not be possible, therefore, determine which sensing sessions to conduct during each visit. The Sample Inspection Itinerary assists the inspected unit or agency by offering specific scope and timeline of the inspection. The inspected unit or agency will assist the Joint IG inspection team in refining the sample itinerary. Finally, the sample itinerary must always include an in-briefing and an out-briefing time. All inspection teams must brief the unit leadership before conducting the inspection and then offer general, non-attributed feedback in the form of an out-briefing following the inspection. A Sample Inspection Itinerary for a one-day inspection visit is as follows:

0800-0815 In-Brief Commander and Unit Leaders
0830-1000 Interview J-1
1000-1130 Sensing Session with O-4s and Above
1000-1130 Review Documents
1130-1230 Lunch
1300-1430 Sensing Session with E-7s and Above
1500-1600 Interview J-3
1600-1630 Out-brief Commander

4. **Notification Memorandum (or Letter).** The Notification Memorandum (the only physical output of this sub-step) officially notifies the affected units or staff agencies that an inspection is forthcoming. Once the inspection team selects the units or staff agencies that will participate in the inspection, the Team Leader (or leaders) will contact each affected unit or staff agency and their IG (if applicable) at least one week before sending the Notification Memorandum. The memorandum officially notifies the

command that an inspection is forthcoming. The memorandum also serves as a precursor to the Detailed Inspection Plan, which will normally follow the Inspection Notification Memorandum by no more than three weeks. The reason for this delay is that the Notification Memorandum will allow the affected units to provide feedback to the Joint IG regarding the timing of the inspection or other issues. If an unforeseen issue arises that requires a change to the Detailed Inspection Plan, the team will have time to make those changes before submitting the final plan.

a. The Inspection Notification Memorandum should include the following information:

(1) Background information about the inspection's origin.

(2) Purpose of the inspection.

(3) A listing of the units the team will visit by location (do not assign dates to these inspections since the calendar may change as a result of feedback the team receives from the affected units).

(4) The Inspection Objectives.

(5) The basic methodology for the inspection (outline the information-gathering domains employed such as document review, sensing sessions, interviews, observation, and questionnaires or surveys).

(6) The basic timeline (the minimum information included are the dates for actual execution phase, the projected out-briefing to the commander, and the date when the Final Report must be complete).

(7) Include a copy of the signed Inspection Directive as an enclosure.

b. See the next page for a sample Inspection Notification Memorandum. Each affected unit must receive a signed copy of this memorandum. PDF files sent via email are the most efficient means of distribution while facsimile and messenger are the least efficient.

COMMAND LETTERHEAD – Sample Inspection Notification Memorandum

20 September ____

MEMORANDUM NOTIFICATION SEE DISTRIBUTION

SUBJECT: Notification of the Individual Augmentee Sourcing Process Inspection

1. BACKGROUND: On 12 August ____, the Combatant Commander directed the Joint Command Inspector General to conduct a systemic inspection of undermanning of Individual Augmentees (IA) within JTFs, X-ray, Yankee, and Zulu. The Combatant Commander signed the Inspection Directive on 24 August ____ (see enclosure).

2. PURPOSE: The purpose of this inspection is to determine why JTFs are consistently undermanned with regard to IA personnel.

3. INSPECTED UNITS: The units and staff agencies affected by this inspection are as follows:

- a. JTF X-ray
- b. JTF Yankee
- c. JTF Zulu

4. OBJECTIVES: The objectives for this inspection are as follows:

- a. Determine if there is a gap in the IA personnel sourcing system.
- b. Determine if J-1 personnel are properly trained.
- c. Determine readiness and workload impact due to the undermanning of IA billets.

5. METHODOLOGY: The baseline methodology for this inspection is as follows:

- a. In-brief the unit leaders and staff members.
- b. Review relevant documents related to IA Manning.
- c. Interview JTF J-1 and J-3
- d. Survey O-4s and above and E-7s and above through sensing sessions.
- e. Out-brief the unit leaders and staff members and provide general feedback.

6. FEEDBACK: The results of this inspection will be contained in a written report distributed throughout the division and installation following the Combatant Commander's approval of the results.

7. TIMELINE: The projected timeline for the inspection is as follows:

- a. Pre-inspection visit: 1 November ____
- b. Visit units: 20 November ____ to 4 December ____

c. Out-brief the Commanding General: 30 December ____

d. Complete the report: 10 January ____

8. INTENT: The intent of the Joint IG Inspection Team is to conduct this assessment with minimal disruption to ongoing training and operations. The team will require a few special arrangements that include the scheduling of sensing sessions, interviews, in-briefings, and out-briefings. The Joint IG will publish a Detailed Inspection Plan NLT 20 October ____.

9. POC for this inspection is CDR Sailor, (703) 123-5678 or DSN: 555-5678, E-mail address@COCOM.mil.

I. M. Army
MAJ, IG
Chief, Inspections Branch

DISTRIBUTION:

Commander, JTF X-ray
Commander, JTF Yankee
Commander, JTF Zulu

FOR OFFICIAL USE ONLY

5. **Sample Fragmentary Order (FRAGO).** In operational theaters, many Joint commands use FRAGOs or other formats to transmit changes to existing base plans. Although the formats may vary, the same basic information included in documents such as the notification memorandum remains the same. A sample FRAGO that incorporates information from a notification memorandum is located below.

SUBJECT: COCOM FRAGO _____ JTF-X, JTF-Y, JTF-Z SUPPORT TO COCOM IG INSPECTION TEAM

ORIGINATOR: _____

DTG: _____

PRECEDENCE: ROUTINE

DAC: GENERAL

(CLASSIFICATION)//REL TO USA,AUS,CAN,GBR//MR

OPER/XXXX//

MSGID/ORDER/USCENTCOM//

TIMEZONE/Z//

NARR/ (U) THIS IS COCOM FRAGO _____ JTF-X, JTF-Y, JTF-Z SUPPORT TO COCOM IG INSPECTION TEAM AND NOTIFICATION OF UPCOMING INDIVIDUAL AUGMENTATION INSPECTION//

GENTEXT/SITUATION/

1. (U) SITUATION. ON 12 AUG XX, CDR COCOM DIRECTED THE IG TO CONDUCT A SYSTEMIC INSPECTION OF THE UNDERMANNING OF INDIVIDUAL AUGMENTATION (IA) WITHIN JTF-X, JTF-Y, JTF-Z.//

GENTEXT/MISSION/

2. (U) MISSION. JOINT IG WILL CONDUCT AN INSPECTION OF JTF-X, JTF-Y, JTF-Z BEGINNING 20 NOV XX AND ENDING 4 DEC XX TO DETERMINE WHY THE JTFS ARE CONSISTENTLY UNDERMANNED.//

GENTEXT/EXECUTION/

3. (U) EXECUTION.

3.A. (U) CONCEPT OF OPERATIONS. JOINT IG BRIEFED CDR, COCOM ON 24 AUG XX AND OBTAINED APPROVAL OF THE METHODOLOGY FOR THE CONDUCT OF THE INSPECTION.

3.B. (U) TASKS.

3.B.1 (U) JOINT IG WILL CONDUCT THE INSPECTION TO DETERMINE THE CONSISTENT UNDERMANNING IN THE FOLLOWING METHOD:

3.B.1.A. (U) IN-BRIEF THE UNIT LEADERS AND STAFF MEMBERS.

3.B.1.B. (U) REVIEW RELEVANT DOCUMENTS RELATED TO IA MANNING.

3.B.1.C. (U) INTERVIEW THE JTF J-1 AND J-3

3.B.1.D. (U) SURVEY O-4 AND ABOVE AND E-7 AND ABOVE THROUGH SENSING SESSIONS.

3.B.1.E. (U) OUTBRIEF THE UNIT LEADERSHIP AND STAFF MEMBERS AND PROVIDE GENERAL FEEDBACK.

3.B.2. (U) JTF-X, JTF-Y, JTF-Z. PROVIDE ALL BOS REQUIRED TO THE JOINT IG INSPECTION TEAM.

3.C. (U) COORDINATING INSTRUCTIONS. DIRLAUTH REQUIRED BETWEEN THE JOINT IG AND JTF-X, JTF-Y, JTF-Z IN ORDER TO FINALIZE INSPECTION PROCESS. KEEP HEADQUARTERS, _____ COCOM INFORMED.

3.C.1 (U) THE INTENT OF THE JOINT IG INSPECTION TEAM IS TO CONDUCT THIS ASSESSMENT WITH MINIMAL DISRUPTION TO OPERATIONS. TEAM WILL PUBLISH A DETAILED INSPECTION PLAN NLT 20 OCT XX THAT WILL INCLUDE THE SCHEDULE FOR THE SENSING SESSIONS, INTERVIEWS, IN-BRIEF, AND OUT-BRIEF.

3.C.2 (U) THE TEAM WILL COORDINATE WITH THE JTF PRIOR TO PUBLISHING THE DETAILED INSPECTION PLAN TO SOLICIT DATES THAT CAN ACCOMODATE THE SCHEDULE//

GENTEXT/ADMINISTRATION AND LOGISTICS/

4. (U) ADMIN AND LOGISTICS.

4.A. (U) CONCEPT OF LOGISTICS SUPPORT WILL REQUIRE CLOSE COORDINATION BETWEEN THE JOINT IG AND JTF.

4.B. (U) JOINT IG WILL PROVIDE JTF-X, JTF-Y, JTF-Z DATA ON NUMBER OF PERSONNEL AND AMOUNT OF EQUIPMENT TO BE HOSTED AT _____./

GENTEXT/COMMAND AND SIGNAL/

5. (U) COMMAND AND SIGNAL.

5.A. (U) _____ RETAINS OPCON/TACON OF OPERATIONS.

5.B. (U) POINTS OF CONTACT.

5.B.1. (U) COCOM IG, _____@XXXXXXXXX.SMIL.MIL.

5.B.2. (U) COCOM IG, MAJ I.M. ARMY DSN _____ VOSIP: _____
MAIL: I.M.ARMY(AT)_____.SMIL.MIL OR CDR SAILOR COCOM
INSPECTION TEAM DSN _____ MAIL: SAILOR(AT)_____.SMIL.MIL

5.C. (U) ACKNOWLEDGEMENT. ALL ACTION ADDRESSEES CONFIRM RECEIPT OF THIS FRAGO BY EMAIL TO _____@_____.SMIL.MIL./

6. Detailed Inspection Plan. Detailed Inspection Plan is the single most important planning document the inspection team will develop and issue to the units or agencies affected by the inspection. This document (the only physical output of this sub-step) requires the greatest amount of detail possible so that, once issued, the document anticipates and answers the questions of all affected commands and units. The focus of the Detailed Inspection Plan is to provide the unit or agency enough information to gather resources and coordinate an itinerary for the visiting Joint IG inspection team. A proper Detailed Inspection Plan leaves very few questions from the units the Joint IG is inspecting. Assign inspection dates to each unit when developing the Detailed Inspection Plan. The team should consider any feedback on dates from the units following their receipt of the Notification Memorandum. The inspection team should consult the command's master training calendar (usually at the G-3/J-3/Training/Operations) to ensure that all affected units will be available to participate during the specified inspection period. Some units may be unable to participate based on their operations schedule. The master training calendar will also allow the inspection team to determine if key training events are occurring that may be worthwhile to schedule for observation. Once the team assigns inspection dates to each unit or agency, the team will complete the Detailed Inspection Plan, which should, at a minimum, include the following:

a. **Directive.** Explain the background of the inspection and list the date that the commander signed the Inspection Directive.

b. **Inspection Goal (Purpose).** Outline once more the overall goal (or purpose) of the inspection.

c. **Inspection Objectives.** List the objectives in their final version.

d. **Task Organization.** Explain how the team is structured for the inspection. List the names of each team member and, if necessary, each member's security clearance.

e. **Inspection Locations and Schedule.** List the units the team, or teams, will visit by location and date.

f. **Inspection Approach.** Explain in detail the team's methodology for conducting an inspection at each location. Normally, the team will state that it will conduct interviews, sensing sessions, document reviews, and observation, or use only two or three of these information-gathering methods. List specifically the types or duties of the individuals, by grade, whom the team wishes to interview or sense. Outline in specific terms the documents the team must review. List the types of events the team would like to observe and evaluate. This level of detail will assist the inspected unit or agency when coordinating and refining the team's itinerary.

g. **Interview Requirements.** This section of the plan should outline the individuals whom the team must interview and sense by duty position and by number. The number of individuals may change by type of unit or location, so the team should consider generating separate requirements for specific units based on their demographics. Tables work best when outlining these requirements (see the sample Detailed Inspection Plan for an example). This section should also outline all classroom and interview location requirements.

h. **Inspection Itineraries.** Be clear about the unit or agency's responsibilities with regard to developing, coordinating, and refining the itinerary. A unit or agency representative should be the ultimate coordinator for everything the team does during the visit. Explain in detail the unit's time requirements for submitting a draft itinerary to the team for review (at least one week before the scheduled visit). Include the Sample Inspection itinerary the team developed as part of the methodology in this paragraph to help guide the unit or agency's efforts. Each unit or agency representative will work with his or her respective Joint IG team chief to craft the right itinerary that will allow the team to accomplish the inspection objectives.

i. **Document Requests.** In most cases, the team will want to review a unit or agency's documents prior to arrival. This paragraph should explain precisely what documents the team must review and how the unit or agency should send them (FedEx, email, regular mail, etc.). The documents should arrive with the first draft of the itinerary.

j. **Resources.** This paragraph should explain to the unit or agency how the Joint IG team plans to travel to the location. The team must also explain any individual equipment limitations as necessary. For example, the team members may have Kevlar helmets and personal field gear available for visiting field sites but may not have proper

cold-weather gear, flak vests, sleeping bags, or other items the team may need for certain events.

k. **Administrative Support Requirements.** List any equipment requirements the inspection team will need while conducting the inspection visit. For example, desk space, computer and printing support, copy-machine support, and so on. The team should mention that the inspected unit or agency might have to provide the team with any additional equipment as required.

l. **Report Completion Timeline.** Specify the dates the team will brief the commander and complete the final report.

m. **Suspense Summary.** Summarize all requirements mentioned throughout the Detailed Inspection Plan for the affected units or agencies. This paragraph will ensure the units or agencies understand all requirements set forth in the Detailed Inspection Plan.

n. **Distribution.** List all affected units or agencies that will receive a copy of the Detailed Inspection Plan. Each unit or agency must receive a signed copy of the Detailed Inspection Plan.

A sample Detailed Inspection Plan for an Individual Augmentation Sourcing Process Inspection appears on the next page.

COMMAND LETTERHEAD – Sample Detailed Inspection Plan

20 October ____

MEMORANDUM FOR SEE DISTRIBUTION

SUBJECT: Detailed Inspection Plan for an Individual Augmentation Sourcing Process Inspection

1. DIRECTIVE. On 12 August ____, the Combatant Commander directed the Joint Command Inspector General to conduct a special inspection of the Undermanning of Individual Augmentees (IA) within JTFs, X-ray, Yankee, and Zulu. The Combatant Commander signed the Inspection Directive on 24 August ____.

2. INSPECTION GOAL. The goal of the inspection is determine why JTFs are consistently undermanned with regard to IA personnel.

3. OBJECTIVES. The objectives for this assessment are as follows:

- a. Determine if there is a gap in the IA personnel sourcing system.
- b. Determine if J-1 personnel are properly trained.
- c. Determine readiness and workload impact due to the undermanning of IA billets.

4. TASK ORGANIZATION. An inspection team from the Combatant Command Inspector General's Office will conduct the assessment by inspecting three Joint Task Forces. The composition of the team and each person's security clearance is as follows:

CDR Sailor (Team Leader) – Top Secret
Maj Airman (Deputy Team Leader) – Top Secret
Maj Marine (TAIG, COCOM J-1 Staff) – Secret

5. INSPECTED UNITS. The inspection will involve the following units and staff agencies on the dates indicated:

20 November: Joint Task Force X-ray
26 November: Joint Task Force Zulu
4 December: Joint Task Force Yankee

6. INSPECTION APPROACH. The Inspection Team will spend one day inspecting each unit. The respective unit will draft an itinerary for the Inspection Team based upon the guidance outlined in paragraph nine of this document. The basic inspection approach at each location will be to in-brief the unit leaders and staff members; review relevant documents related to Individual Augmentation manning in the unit; survey O-4s and above and E-7s and above through sensing sessions; and out-brief the unit leaders and staff members to provide general feedback.

a. **Personnel to Interview** (see paragraph seven below for specific requirements):

- JTF J-1 and J-3
- Officers O-4 and above
- Enlisted E-7 and above

b. Documents to Review in Advance:

- SOPs on IA Sourcing Process
- Joint Manning Documents for JTFs X, Y, and Z
- Current IA Sourcing Process procedures per JP-1, Appendix F
- Written assessments of any readiness gaps due to the undermanning of IA personnel
- Personnel Readiness Reports
- Mission Readiness Reports

c. Events to Observe (as available based upon the day that the inspection team visits the unit):

None

7. INTERVIEW REQUIREMENTS. The following table outlines the specific interview and sensing-session requirements.

	Commander	E-7 and Above	O-4 and Above	Junior Officers	E-5 to E-6	J-1 Officers	J-3 Officers
Individuals Interviewed	1	1				1	1
Sensing Session		10	10				
Total Contacted	1	11	10	0	0	1	1

a. Higher-Level Headquarters Considerations. The number of sensing-session participants will be fewer for each of the categories during visits to higher-level headquarters.

b. Classroom and Interview Location Requirements. Each sensing session will require a classroom or similar facility that is removed from the unit's normal work location. The area must be relatively quiet and free from interruptions and telephone calls. In addition, the room will need no fewer than 12 chairs or desks formed into a "U" shape. The unit should schedule 90-minute blocks for each sensing session. Individual interviews can occur in the interviewee's office or in a similar location free from interruptions and telephone calls. The unit should schedule these interviews to last no more than one hour.

8. INSPECTION ITINERARIES. The Inspection Team requests a draft itinerary that meets the requirements listed in paragraphs six and seven no fewer than 10 days before the day of the scheduled inspection. These itineraries should go directly to the Team Leader (see paragraph four). The Team Leader will work with each unit to determine which itinerary best allows the Inspection Team to meet the objectives listed in paragraph three. The intent of each inspection team is to conduct this assessment with minimal disruption to ongoing training. The team requires no special calendar arrangements except for the scheduling of group sensing sessions, interviews, and in- and out-briefings. A sample itinerary for a one-day unit inspection visit is as follows:

0800-0815 In-Brief Commander and Unit Leaders
0830-1000 Interview J-1
1000-1130 Sensing Session with O-4s and above
1000-1130 Review Documents
1130-1230 Lunch
1300-1430 Sensing Session with E-7s and above
1500-1600 Interview J-3
1600-1630 Out-brief Commander

9. PRE-INSPECTION DOCUMENT REQUEST. The Inspection Team requests each unit send the following documents – as they apply – to the inspection Team Leader:

- JTF Joint Manning Document (JMD)
- JTF Individual Augmentation requirements
- JTF Readiness Reports

The intent of this document request is to view only those documents that relate to Individual Augmentation. Avoid sending documentation that does not apply to Individual Augmentation. These documents are due to the Inspection Team Leader not later than 10 days before the scheduled inspection. Electronic versions of these documents sent via email are acceptable.

10. RESOURCES. The Inspection Team will travel to each unit using locally procured transportation of one HMMWV. The team members do not require any additional transportation. Each team member will have required personal protective equipment. The unit will provide other special equipment to the team members as required.

11. ADMINISTRATIVE SUPPORT REQUIREMENTS. The Inspection Team will require the following administrative support assistance from each unit:

- a. Desk space for three or more people
- b. Access to a computer
- c. Printer and copying support

12. REPORT COMPLETION TIMELINE. The results of the inspection will appear in a written report distributed throughout the Joint Task Force's area of responsibility and following the Combatant Commander's approval of the results. The schedule to complete the report is as follows:

- a. Out-brief the Combatant Commander: 30 December ____
- b. Complete report: 10 January ____

13. SUSPENSE SUMMARY. A summary of the suspenses contained in this document is as follows:

- a. Draft itineraries due to the Inspection Team no fewer than 10 days before the date of the scheduled inspection.

b. Requested documents due to the Inspection Team not later than 10 days before the day of the scheduled inspection.

14. POC for this inspection is CDR Sailor, (703) 123-5678 or DSN: 555-5678, E-mail address@COCOM.mil.

I. M. Army
MAJ, IG
Chief, Inspections Branch

DISTRIBUTION:
Commander, JTF X-ray
Commander, JTF Yankee
Commander, JTF Zulu

Section 5.5

Preparation Phase Step 5. Train Up

1. **Training for the Inspection.** Once the Joint IG inspection team completes and issues the Detailed Inspection Plan, the team can focus its efforts on training for, and preparing to conduct, the inspection. The team must perform a series of tasks and generate certain key products as follows:

- a. Conduct additional training on the inspection topic as required.
- b. Develop specific duties and responsibilities for the temporarily assistant IG (TAIG) personnel.
- c. Develop information-gathering tools such as interview questions, sensing-session questions, and direct-observation spot-report formats.
- d. Develop standard in-briefing and out-briefing formats.
- e. Conduct equipment inventories and rehearsals.
- f. Rehearse interviews and sensing sessions if feasible.

The physical outputs of this step are the TAIG responsibilities, information-gathering tools, and standard in-briefing and out-briefing formats.

2. **Additional Training.** After planning in detail for the inspection, the Inspection Team Leader may realize that the Research step did not provide all of the information the team members require to accomplish the inspection successfully. The Team Leader may decide to ask the TAIGs, as subject-matter experts, to conduct training for the Joint IG team members. The Team Leader may also request training from external subject-matter experts who can complement the information provided by the TAIGs. Another technique is to hold round-table discussions with the team members to discuss key aspects of the inspection topic. The sources for these discussions should be the applicable regulations and manuals governing the inspection topic. Once the Team Leader feels comfortable the team knows enough to conduct the inspection effectively, they will “certify”, in a subjective sense, the team’s ability to go forth and inspect units or agencies. No standard certification process exists or is necessary.

3. **Duties of TAIGs.** The Team Leader should capture in writing the duties and responsibilities of all TAIGs to avoid confusion as the inspection progresses. A good technique for presenting TAIGs with these responsibilities is to conduct a short IG training session with them. The Joint IG team members can brief the TAIGs on Joint IG responsibilities, the notion of confidentiality, and the use of Joint IG records. The Team Leader can brief the TAIGs on their responsibilities and solicit their immediate feedback. The Team Leader should end the session by swearing in the TAIGs (see [The Joint IG Concept and System Guide](#)) as Temporary Assistant IGs. Below is a list of TAIGs responsibilities for conducting the Individual Augmentee (IA) inspection:

- a. Primary responsibility is to review all Joint Manning Documents gathered as part of the inspection and then to write brief assessments of each document in the relevant Trip Reports.
- b. Secondary responsibility is to assist in developing interview questionnaires for JTF J-1 and J-3 personnel.
- c. Serve as sensing session recorders as necessary.
- d. Provide continuous expert advice to the Joint IG team members throughout the conduct of the inspection.
- e. Assist the Team Leader in reviewing and critically analyzing each chapter of the Final Report to ensure the findings are logically sufficient and in line with current doctrine and practice.

4. Developing Information-Gathering Tools. The team may need to develop information-gathering tools to execute the inspection. Some of the information-gathering tools are interview and sensing session questions, observation spot-report formats, surveys or questionnaires, and guidelines for document review.

a. Interview and Sensing Session Questions. The team members must develop the interview and sensing session questions based upon the Sub-Tasks created for each objective during Step 4. The questions should answer the basic requirements for those Sub-Tasks. The team members can design questions that, when answered, will provide information relevant to one or more Sub-Tasks. The questions must be open-ended in nature and offer the opportunity for follow-up questions. Close-ended questions requiring only a “yes” or “no” response will not lead the inspection team to the root causes of any compliance or non-compliance issues. The inspection team must develop all questions with the intended audience clearly in mind. In most cases, the team will develop two sets of interview questions and two sets of sensing session questions (one set each for senior individuals and another set for more junior people).

The interviewer or sensing session facilitator must never treat the questions as a checklist but instead allow them to guide a free-flowing discussion leading to more in-depth and insightful information. The Joint IG must keep in mind the pitfall of using checklists for any type of inspection as they fail to allow a Joint IG to get at the root cause of any problems. The following set of interview questions is for an Undermanning of Individual Augmentees (IA) inspection:

SAMPLE INTERVIEW QUESTIONS

Interview: JTF J-1 / J-3

Interviewee _____ Unit _____ Date _____
Duty Position _____ Time in Current Position _____

1. Describe Joint manpower requirements development in your organization and your involvement in the process. (Sub-Tasks 1.2)
2. Describe the manpower management process within your organization. (Sub-Task 1.2)
3. Describe how the IA Sourcing Process works. (Sub-Task 1.1)
4. Describe how you determine overall JTF manning levels and IA manning levels. (Sub-Tasks 1.1 and 1.2)
5. How do you calculate overall personnel readiness? (Sub-Tasks 2.1)
6. How do you report overall personnel readiness? (Sub-Task 2.1 and 3.2)
7. How many Joint Task Force J-1 / J-3 positions have you held? (Sub-Task 2.1)
8. What part of the IA sourcing process do you feel is not working properly? (Sub-Task 1.2)
9. How responsive is the IA sourcing process to your command's needs? (Sub-Task 1.1)
10. What other challenges are there concerning IAs? (Sub-Task 1.1)
11. How many „gapped“ IA billets are there in this JTF? (Sub-Task 3.1)

Notice that the questions are focused on a conversation with one person and that the questions lend themselves to a more open discussion. The interviewer does not have to ask each question in sequence but can allow the interviewee to expand upon the discussion naturally; the interviewer can always ask the questions not covered at a later time. The relevant Sub-Tasks follow each question to show the direct link between the questions the interviewer is asking and the information required answering the Sub-Tasks. In this case, Sub-Task 1.2 means Sub-Task 2 of Objective 1.

Since an interview normally lasts one hour, the team should develop no more than 10 or 11 questions for an interview. In this case, the interview questions are focused on senior individuals. A second set of questions for junior leaders will be slightly different; however, many of the questions may remain the same. These same guidelines apply for the development of sensing session questions. The greatest difference is that the audience is now several people and not simply one person. The sensing session questions should facilitate a group discussion. A sample set of sensing session questions for an Undermanning of Individual Augmentees (IA) inspection follows:

SAMPLE SENSING SESSION QUESTIONS

Sensing Session / Focus Group: O-4 and Above

Duty Positions _____ Unit _____ Date _____
Interviewees' Grade Structure _____

1. What Individual Augmentee skill sets are you lacking within your department / division? (Sub-Task 3.1)
2. Has the lack of IA skill sets impacted mission readiness and, if so, how? (Sub-Task 3.1 and 3.2)
3. How many IA billets are „gapped“ within your department / division? (Sub-Tasks 3.1)
4. What is the workload increase based on the „gapped“ IA billets? (Sub-Tasks 3.2)
5. How does the additional workload impact training? (Sub-Tasks 3.2)
6. How does the additional workload impact mission readiness? (Sub-Task 3.2)
7. How does the lack of IA personnel directly impact your mission? (Sub-Task 3.2)
8. What actions have the command taken to compensate for being undermanned? (Sub-Task 2.1)
9. What actions have your department / division taken to compensate for being undermanned? (Sub-Task 1.1)
10. What do you think is the best course of action to correct IA undermanning? (Sub-Task 1.2)

Some of these questions are similar to the interview questions presented earlier, but the focus of these questions is to promote a group discussion. Sensing sessions last longer than interviews (90 minutes or less), but the number of questions should still remain at around 10 or 11. More people will be talking, so the facilitator will require more time.

b. Observation Spot-Report Formats. Since direct observation is one of the more important information-gathering techniques available to the Joint IG, the inspection team should consider developing a standard format for capturing information gleaned from observing training or other events. The format can pose questions that will jog the observer's memory about the topic while leaving enough space to capture comments and descriptions. An example of a spot-report format (Figure 5-3) for a Radio Frequency Identification (RFID) Tag Usage inspection follows:

RFID Tag Usage - TYPE OF EVENT:					UNIT	SITE	YOUR NAME		
INDIVIDUALS PRESENT	CC LEVEL	JTF LEVEL	COM LEVEL	UNIT	TOTAL OFFICERS	TOTAL NCOS	TOTAL ENLISTED	TOTAL CIVILIANS	TOTAL
SUPERVISORS									
LOGISTICIANS									
DURATION OF OBSERVATION:					SUPERVISOR TO PERSONNEL RATIO:				
RFID TAG USAGE WORKSHEET									
	# CONTAINERS	TAG PRESENT/SCANNED	RETROGRADE CTR TAGGED	EXCESS TAGS PROCESSED FOR TURN IN	REMARKS				
SHIPMENT 1									
SHIPMENT 2									
SHIPMENT 3									
SHIPMENT 4									

**Figure 5-3
Spot Report Format**

c. **Surveys and Questionnaires.** Surveys and questionnaires are the same thing and are simply interview questions converted to a close-ended format. These questionnaires should have "yes" or "no" questions or a multiple-choice answer. However, their purpose is to determine if something is occurring or not occurring in a unit or agency and not necessarily to discover the root cause of any problems. Yet the inspection team may design some of the questions to help get at some type of root cause, but that root cause may only be superficial in nature. Surveys and questionnaires are best used when the Joint IG team only requires a sampling of basic information from a certain population. Individuals will complete and then submit these questionnaires with little or no interaction with the respondent.

d. **Guidelines for Document Review.** Prior to receiving documents from the unit, it may be helpful to develop a set of guidelines for reviewing the documents requested. The team should use the tasks and sub-tasks to help focus the review of the documents on the inspection topic while maintaining awareness for other over-arching items of interest.

5. **Standard In-Briefing and Out-Briefing Formats.** The Team Leader of each team (if operating in two or more teams) must always brief the leadership of the command or unit the team is inspecting immediately upon arrival. This initial briefing is the in-brief, which outlines the basic purpose and methods behind the inspection. Following the inspection, the Team Leader will conduct an out-brief with the same leadership, offering

general feedback about what the inspection team found or learned. In an effort to ensure uniformity and consistency, the team must develop standard formats for these two briefings. Much of the basic inspection information in these briefings will come directly from the Concept-Approval Briefing.

a. **In-Briefing Format.** The standard in-briefing should be informative, focused, and brief. The presentation is strictly informational and should not include any information that will raise questions among the command or unit's leaders. The in-briefing should include the following:

- (1) Inspection Goal.
- (2) Inspection Intent (should include a bullet that states that the inspection will be open and discreet with no surprises).
- (3) Inspection Objectives.
- (4) Task Organization.
- (5) Inspection Concept (one slide per phase if required).
- (6) Special-Interest Item (if applicable).
- (7) List of locations and units that the team (or teams) will visit.
- (8) Inspection Timeline (locations to visit by month and phase).

b. **Out-Briefing Format.** The standard out-briefing will comprise two parts. The first part will review information from the in-briefing covering the inspection's overall purpose, and the second part will include feedback from the inspection. The out-briefing must be fully redacted for all attribution save for the good news observations. The out-briefing format should include the following:

- (1) Inspection Goal.
- (2) Inspection Intent (should include a bullet that states that the inspection was open and discreet with no surprises).
- (3) Inspection Objectives.
- (4) Training or Events Observed and Assessed (this slide will quantify the numbers of individuals interviewed and sensed, the number of documents reviewed, and the number of events observed).
- (5) Good News Observations (this slide should list no fewer than three positive features of the inspection and can include the names of individuals or units).
- (6) Training or Events Observed (this slide will include bullets that comment upon the training or other events observed by the inspection team).

(7) Documents Reviewed (this slide should offer some brief comments about the results of the inspection team's analysis of the command's or unit's documents).

(8) Interviews and Sensing Sessions (this slide, or slides, should provide unprocessed comments taken directly from interviews and sensing sessions; the Team Leader must emphasize to the leadership these slides are not the result of Joint IG analysis but are simply restated, but relevant, comments from anonymous individuals throughout the command).

(9) Summary Slide (this slide should not attempt to endorse or validate any one unit's particular program or operation; the Final Report will cover that issue).

6. Interview and Sensing Session Rehearsals. The inspection team's interviewers and sensing session facilitators should practice their introductions, room set up, and overall technique before conducting the Pre-Inspection Visit. Rehearsals of this nature will help the team members shake out some of the basic details of conducting an interview and sensing session. Sensing session facilitators should discuss their technique with their recorder to ensure both individuals have the same focus and intent. Interview and sensing session rehearsals may be difficult to conduct prior to executing the Pre-Inspection Visit. The team members can practice interviews with each other with some ease, but gathering enough individuals to conduct practice sensing sessions may not be feasible.

7. Equipment Inventories and Rehearsals. Inspection teams should consider the following listed materials when constructing an IG travel book or bag.

- a. Smart book with:
 - Inspection Directive (at least 10 copies)
 - Inspection concept / plan
 - Notification Letter
 - Detailed Inspection Plan
 - Methodology
 - Standard in-briefing and out-briefing formats
 - Sensing-session / focus group and interview questions
 - Surveys and questionnaires (required number of copies)
 - Observation spot reports (at least 10 copies)
 - Telephone / email contact roster of team members
- b. Security memorandum from the unit security manager (if applicable)
- c. Joint IG official vehicle placard
- d. DD Form 1610 (if traveling)
- e. Government credit card (if traveling)
- f. Identification card (or Common-Access Card)
- g. Identification tags
- h. Itinerary
- i. Plane tickets (if traveling)
- j. Lodging confirmation (if traveling)
- k. Rental car confirmation (if traveling)
- l. Passport (if traveling overseas)
- m. Country clearance (if traveling overseas)

- n. Immunization / shot records (if traveling overseas)
- o. International driver's license (from American Automobile Association) (if traveling overseas)
- p. Copies of all applicable standards, regulations, and manuals
- q. The Joint IG Inspections Guide from the Joint IG School
- r. Laptop with CD drive and disks
- s. Cellular phone with power adapter (Team and Sub-team Leaders)
- t. Desk-side briefing binder
- u. Office supplies (pens/markers/binder clips/stapler/tape/folders/highlighters)
- v. Briefing pointer
- w. Personal business cards

Each Team Leader should conduct a rehearsal inventory of this equipment prior to conducting the Pre-Inspection Visit and the actual visits to the inspected units. The intent behind carrying these items is to reduce the Joint IG team's resource demands on the inspected units or agencies.

Section 5.6

Preparation Phase

Step 6. Pre-Inspection Visit

- 1. Purpose of the Pre-Inspection Visit.** Pre-Inspection Visits may be necessary to validate and refine the inspection team's methodology and information-gathering tools (interview questions, etc.).
- 2. Selecting a Unit for the Pre-Inspection Visit.** The inspection team should identify the Pre-Inspection unit, or units, during the Plan-in-Detail step (Step 4). The unit or command should be a representative, median example of the type of unit or command the inspection team will visit. For example, if three of the eight activities the team will visit are JTFs, then the team should select a JTF for the Pre-Inspection Visit. The unit must not be part of the planned inspection. If the inspection team will visit two or more types of units or commands using separate methodologies for each one, then the inspection team must conduct a Pre-Inspection Visit with each type of unit or command to validate each methodology.
- 3. Notifying the Units or Commands Selected for the Pre-Inspection Visit.** Notification of the Pre-Inspection Unit (or Units) should occur at the same time the inspection team notifies the units selected for the actual inspection. The Pre-Inspection Unit should receive a Notification Letter and a Detailed Inspection Plan. The primary difference is these documents will only identify the unit (or units) selected for a Pre-Inspection Visit. Some of the information in each document may need to be altered to facilitate the shorter lead time the Pre-Inspection Unit may face. In most cases, the inspection team will work more closely with the Pre-Inspection Unit for itinerary development and other requirements. The planning documents must state that the unit is a Pre-Inspection Unit and the information gleaned from the visits will not be used for the inspection or be included in the Final Report.
- 4. Conducting the Pre-Inspection Visit.** The inspection team should treat the Pre-Inspection Visit as a full dress rehearsal for the actual inspection. The team should arrive prepared to execute the methodology precisely as planned. Explain to the leadership at the in-briefing that the visit is a pre-inspection exercise, but this fact should not alter the team's approach in any way. The team members may solicit feedback about the conduct of the inspection from the unit's participants during the course of the visit, but the unit should not see a visible difference between the team's planned methodology and the actual execution of that methodology. The team must also provide feedback to the unit at the out-briefing so the unit may benefit from participating in the pre-inspection exercise.
- 5. Refining the Methodology and Information-Gathering Tools.** Once the Pre-Inspection Visit, or Visits, is complete, the inspection team should return to the Joint IG shop and refine the methodology and information-gathering tools as necessary. The team members should gather and share any information that may lead to improved versions of the interview questions, sensing session questions, etc. In most cases, the basic methodology will not change, just the detailed approach. The team should also complete a full Trip Report for practice and, more importantly, for record, even though

the information will serve no purpose in the Final Report. After the adjustments to the tools are complete, the inspection team is ready to visit the units. Figure 5-4 shows the steps with the associated completed items.

Step 1	Step 2	Step 3	Step 4	Step 5	Step 6
Inspection Purpose	Concept Letter	Concept Briefing	Sub-tasks Identified	Information Gathering Tools	Refine Methodology
Inspection Objectives		Inspection Directive	Methodology Task Org Baseline Itinerary	Rehearsals	Refine Information Gathering tools
			Notification Letter		
			Detailed Inspection Plan		

**Figure 5-4
Preparation Phase and Outputs**

Chapter 6

Execution Phase

- Section 6.1 Step 7: Visit Commands
- Section 6.2 Step 8: In-process Review (IPR)
- Section 6.3 Step 9: Update Commander
- Section 6.4 Step 10: Analyze Results and Crosswalk
- Section 6.5 Step 11: Out-brief Proponent

Chapter 6

Execution Phase

1. **Purpose.** This section discusses the five steps of the Execution Phase within the Inspections Process.

2. **Execution Phase.** The Execution Phase of the Inspections Process represents the heart of the inspection since inspectors will spend this phase gathering and analyzing information. The Execution Phase has five discrete steps (see Figure 6-1), but some of these steps may be repeated several times before progressing to the next step (for example, Visit Commands and In-Process Review). The five steps of the Execution Phase are as follows:

- a. Visit Commands
- b. In-Process Review
- c. Update the Commander
- d. Analyze Results and Crosswalk
- e. Out-Brief the Proponent

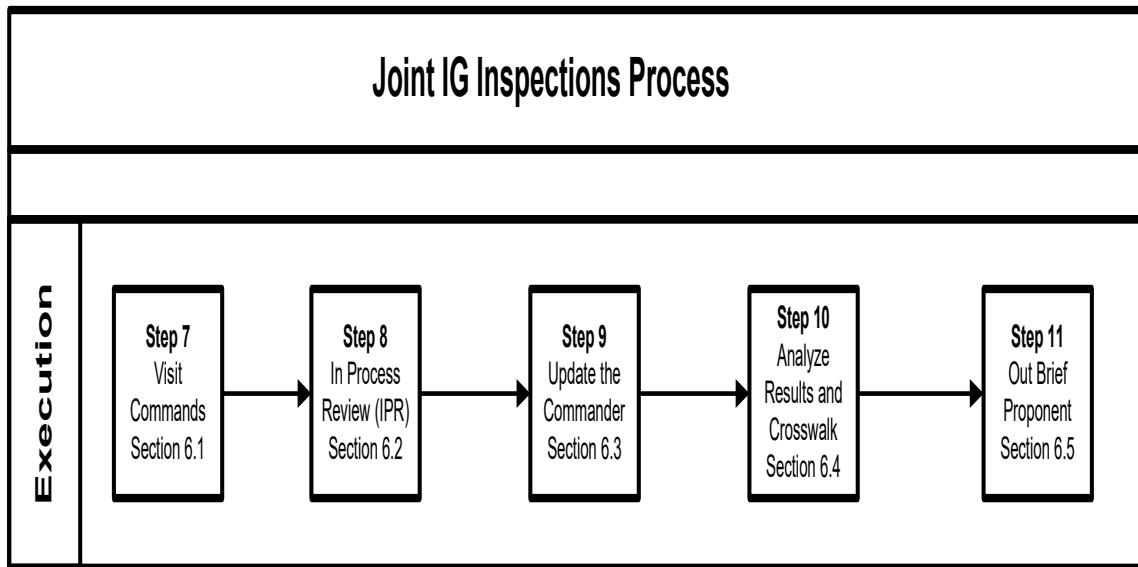

Figure 6-1
Execution Phase

Section 6.1

Execution Phase Step 7. Visit Commands

1. **Visit Units.** The Joint IG inspection team will put into practice their validated methodology and information-gathering tools during this step of the Execution Phase and repeat this step at each unit. The team will arrive ready to conduct an in-briefing and execute the itinerary developed in the Detailed Inspection Plan. Visits to units or agencies may last one day or several days as the team members gather information by conducting interviews and sensing sessions, administering questionnaires or surveys, observing events, and reviewing documents, all in accordance with the inspection methodology, and consistent with the inspection objectives. At the end of each day, team members should work on developing a trip report (explained in greater detail later in this section). The team will conduct In-Process Reviews (explained in greater detail in Section 6.2) at various points scheduled during the visit to share and consolidate information gathered by the team. The information gleaned from the In-Process Review will be instrumental in updating the Joint IG's Directing Authority and developing an out-briefing for the unit's leadership upon the team's departure.

2. **Trip Reports.** The team must craft a detailed Trip Report capturing the critical information gleaned during the visit. The Trip Report should be in memorandum format and include a paragraph for each interview and sensing session conducted, each document reviewed, and each event observed. These paragraphs will appear in the Trip Report as an observation and will include four possible types of information:

a. **Raw-data information.** Unprocessed examples of what the Joint IG saw, read, or heard.

b. **Synthesized information.** Sentences combining raw-data information in an effort to summarize the information.

c. **Analyzed information.** Sentences critically examining and processing raw-data information in an effort to glean greater meaning from the data.

d. **Inspector's assessment.** Sentences capturing the Joint IG's sense or impression of the event observed or people interviewed.

The Trip Reports will serve as primary-source documents for writing the Final Report, so ensure they are thorough, accurate, and complete. Writing the Trip Report immediately after an inspection visit allows the inspection team to capture more detailed information for the Final Report. The longer the inspection team waits before writing a Trip Report, the more information the team will lose. Hand-written notes will become more undecipherable, and the individual team members will begin to forget important points they might not have captured in their notes. In addition, the Trip Report also serves as a record of the Joint IG team's visit to the unit. The inspection team will have detailed Trip Reports serving as the basis for a detailed Final Report written much later if an unforeseen event occurs causing the commander to cancel the inspection. If the

team never finishes the inspection, then the Trip Report still serves as a detailed record of the information gathered from each unit up to the point the inspection ended.

3. Writing the Trip Report. The Team Leader or Team Deputy is normally responsible for setting writing deadlines, compiling the completed paragraphs, and then editing the final product for content and grammar. Each member of the team must contribute to the report.

a. **Setting a Writing Deadline.** The Team Leader or Team Deputy is responsible for setting a clear and reasonable writing deadline. This deadline is aimed at completing the Trip Report before embarking upon the next inspection visit. Since most team members will only have one or two paragraphs to write, a one-day deadline is often quite reasonable.

b. **Writing the Sub-Paragraphs.** Each team member must write paragraphs capturing the results of interviews, sensing sessions, observations, and document reviews conducted. Everyone must do his or her own work to ensure data and information is not lost. Each team member must ensure he or she lists the Sub-Tasks applicable to the information contained within each sub-paragraph. These paragraphs must follow the inspection team's prescribed Trip-Report format precisely.

c. **Compiling the Trip Report.** The Team Leader or Team Deputy will compile the draft Trip Report (electronically if possible) and edit for comprehension, readability, format, and grammar. The Team Leader or Team Deputy will then print a final copy for signature.

d. **Signing and Approving the Trip Report.** The Team Deputy will submit the Trip Report to the Team Leader for final review and signature. If the team is organized into sub-teams, the sub-team leader will sign and approve their own team's Trip Report and send a copy to the overall Team Leader for information purposes only. All original, signed copies of Trip Reports will go into the inspection team's archive file or book along with a copy of the unit out-briefing slides.

A trip report is required for every visit. In the sample scenario, there would be a Trip Report required for each of the three JTFs. Below is a sample of one Trip Report for an Individual Augmentation (IA) inspection.

COMMAND LETTERHEAD – Sample Trip Report

20 Nov _____

MEMORANDUM FOR RECORD

SUBJECT: Undermanning of Individual Augmentees (IA) within JTF X-ray

1. **General.** One team composed of two Joint Inspectors General and one member of the COCOM J-1 Staff as a Temporary Assistant Inspector General (TAIG) conducted an assessment of the IA sourcing process within JTF X-ray.

2. **Team Composition.**

Team:

CDR Sailor (AIG)

Maj Airman (AIG)

Maj Marine (TAIG, COCOM J-1 Staff)

3. **Scope of the Visit:** Determine why IA manning shortfalls are occurring within JTF X-ray and its impact to operational readiness via interviews with J-1 and J-3 personnel and sensing sessions with officer and enlisted leadership.

4. **Observations.**

a. **Interview Findings**

(1) **Observation 1** (Sub-Tasks 1.1, 1.2, 2.1). **Interview with the JTF J-1 (LCDR Hazegrey).** JTF X-ray J-1 concurred their IA requirements are not being filled with a face-to-face relief, if at all. This shortfall adds additional training requirements to the staff and additional workload to remaining personnel. JTF J-1 was not knowledgeable enough about the IA sourcing process to articulate clearly any gaps in the process. Suggested reviewing ECRC in Kuwait because he heard the ECRC has a reputation of diverting personnel once they enter the AOR. LCDR Hazegrey is filling his first J-1 position and is Navy trained; he appeared overwhelmed and under-trained. He had concerns with properly reporting personnel readiness and use of the Joint Manpower Document as a personnel management tool.

(2) **Observation 2** (Sub-Tasks 1.1, 1.2, 2.1). **Interview with the JTF J-3 (Maj Green).** JTF X-ray J-3 considers the J-1 not properly trained for the J-1 function. Too much lag-time between J-3 personnel change requests and execution by J-1. J-3 feels the JMD is consistently behind the power curve when there is a change to mission requirements. J-3 understands the IA Sourcing process but does not have the time to “hold the J-1’s hand” in the execution of JMD change requests.

b. **Sensing Sessions**

(1) **Observation 1** (Sub-Tasks 2.2 and 3.1). **Sensing Session with Junior Officers and Non-Commissioned Officers (NCOs).** Both officer and enlisted personnel noted increased training demand on all units due to being undermanned. The readiness officer was in the sensing session and noted a decline in personnel readiness over the past three months. Enlisted leadership spending too much time training the few incoming IA personnel due to lack of proper training within the IA pipeline for the skill sets required at the unit level. JTF X-ray enlisted leadership did not feel skill-set requirements are properly captured in the JMD.

(2) **Observation 2** (Sub-Task 3.1). **Sensing Session with Training Officers and Senior NCOs.** Training officer and senior NCOs noted longer working hours and mission creep with fewer personnel on station. There is less down time between missions, and they think it is over-stressing JTF personnel. Finding time to train is difficult due to the high operational tempo. One senior NCO noted that he sends more personnel to medical now than he did five months ago, and he thinks it is due to stress of the high operational tempo with little or no down time to recover. Overall, leadership appears to be aware of the additional workload due to under manning of IA personnel. Not receiving IA personnel with proper skill sets adds to additional training requirement at the unit level.

c. Documents Reviewed:

(1) **Observation 1** (Sub-Task 3.2). **JTF Joint Manpower Documents.** JTF X-ray was manned at 93% of overall funded requirements; however, IA manning was at 72%. The gap in IA manning significantly degrades mission readiness in the area of convoy operations, security watch detail, and fire suppression support teams. The IA gap requires additional training for non-IA personnel in areas outside of their mission requirement.

(2) **Observation 2** (Sub-Task 3.2). **Personnel Readiness Trends.** Over the past three months, personnel readiness has steadily declined from state Bravo to Charlie. According to the J-1 and the Readiness Officer, JTF X-ray is not forecast to increase personnel readiness to state Bravo until February / March time frame.

(3) **Observation 3** (Sub-Task 3.2). **Mission Accomplishment.** Reviewed mission tasking and operational tempo over the past three months and found a steady increase in mission sorties and an expansion of mission operational requirements. Based on the expansion of mission operational requirements and a cross-check of personnel skill sets on board, there appears to be a mission-to-skill-set disconnect. The JMD or mission statement does not indicate the requirement for skill sets to conduct long-range and extended convoy operations conducted by JTF X-ray.

5. **Good News Story.** JTF X-ray has a strong training program and has been very flexible and creative in meeting mission tasking. Senior enlisted leadership is fully engaged in mission training and has requested SME training from other JTFs as required based on new mission tasking orders.

6. **Additional Information.** Scope of IA sourcing process requires Joint IG staff to expand the inspection to review ECRC operations and decision matrix for diverting IA personnel from original orders.

//original signed//
J. P. Sailor
CDR, IG
Inspections Branch

Encl:
Out-briefing Slide Packet

[Footer for all pages:]

FOR OFFICIAL USE ONLY

Take note of the level of detail involved in each paragraph. As the Joint IG writes out his or her observations using notes taken during the visit, the Joint IG will begin to recall details he or she failed to capture on paper. These details may prove essential to the findings in the Final Report. The more detail each inspector adds, the better! The Good News information located in paragraph five is from the out-briefing (not presented here). Also, note the footer that must appear at the bottom of each page.

4. Inspector General Information. Trip Reports are not redacted (edited) for attribution. Instead, Trip Reports list units and interviewees by name in case the team members need to know the source of the information for potential cross-walking issues at a later time. Since Joint IGs must protect this information in order to protect confidentiality, a footer must appear at the bottom of each page (see the example above) reminding a Joint IG (and others) the information is FOUO (For Official Use Only). Only redacted reports, or reports edited for attribution, can be released under Exemption 5 of the Freedom of Information Act (FOIA).

Section 6.2

Execution Phase

Step 8. In-Process Review (IPR)

1. **Purpose of the IPR.** An In-Process Review is a meeting of inspection team members for the primary purpose of compiling and sharing information gathered during a single or multiple inspection visits. By sharing key information at the IPR, team members can gain a perspective on where the inspection results are leading them and what patterns and trends are beginning to appear. The IPR is an organized, well-prepared meeting with an agenda and a means of collecting data for open consideration by all team members. The IPR should last no more than 90 minutes. Generally, Joint IGs convene IPRs for two different reasons and purposes:

a. **Produce an Out-briefing.** Conduct an IPR immediately following an inspection visit to a unit or command with the sole purpose of sharing information to produce an out-briefing. Conducting daily team IPRs at the inspection location is essential. If the visit lasts for two or three days, the team must gather at the end of each day to share data gleaned from the day's information-gathering activities. The IPR information allows the Team Leader to direct team members to pursue issues that arise or conduct cross-walking efforts to verify or substantiate existing information. If the visit lasts only one day, the team will conduct one IPR and produce the out-briefing at the end of the meeting. The information shared during the IPR feeds directly into the out-briefing. The IPR Worksheet completed at the end of the inspection visit will provide the Team Leader with the necessary information to craft a useful and focused out-briefing presentation.

b. **Identify Trends and Patterns.** The purpose of these IPRs will be to share information gathered from several units so the team can identify developing trends and patterns. The Team Leader of the overall inspection effort may decide to convene IPRs at the Joint IG office following every third or fourth unit visit. These trends and patterns will provide the basis for feedback to the commander during the mid-inspection update (if requested by the commander).

The out-briefing and trend analysis represent two potential physical outputs of an IPR. IPRs may occur to generate other products as well.

2. **IPR Analysis Tools.** Sharing information during an IPR can be a challenge. The best method for sharing information or developing trends is to develop a method (or methods) for capturing and presenting the information visually so everyone on the inspection team can see the information and discuss it. Two recommended IPR analysis tools are discussed below.

a. **IPR Worksheet.** This worksheet (See Figure 6-2) brings together the key points all members of the team gleaned from their interviews, sensing sessions, document reviews, and observations at a particular unit or units. When multiple teams come together periodically during the course of the inspection to share information, the best way to complete the worksheet is to focus on one team at a time. If a team is conducting a unit-level IPR, the best method is for each team member to complete the

worksheet. In all cases, a designated scribe will capture the information by inspection team or team member, by objective, and by information-gathering domain (interviews, sensing sessions, etc.). The best technique for capturing and sharing this data is to draw an IPR Worksheet on butcher-block paper and add everyone's comments. Once the IPR is over, the Team Leader can transfer the data to an electronic version of the worksheet for later dissemination. A sample IPR Worksheet is as follows:

SAMPLE - IPR WORKSHEET

Location(s): _____ Date: _____

Team / Team Member	Objective 1	Objective 2	Objective 3	Objective 4	Objective 5

**Figure 6-2
IPR Worksheet**

The inspection team may add more rows to the worksheet as necessary based upon the number of teams or the number of team members. The scribe can also write the objective directly below the objective headings.

b. **Trends Analysis Worksheet.** This sheet (See Figure 6-3) allows the assembled inspection team to review present and past IPR Worksheets and list any obvious trends. A designated scribe should list the trends by unit (using butcher-block paper) and then revisit each one during subsequent IPRs. Some trends may fade or fall away over time and become invalid. This information proves extremely useful when developing a mid-inspection IPR briefing for the commander. Once the IPR is over, the Team Leader can transfer the data to an electronic version of the Trends Analysis Sheet for later dissemination. A sample Trends Analysis Worksheet follows:

SAMPLE - TRENDS ANALYSIS

TREND	UNIT	UNIT	UNIT	UNIT	UNIT

**Figure 6-3
Trends Analysis Worksheet**

3. **Conducting the IPR.** The overarching purpose of all IPRs is to share information; however, the output of each IPR may vary. IPRs conducted at the end of a unit visit will produce an out-briefing; however, IPRs conducted periodically at the Joint IG office during the course of the inspection will consider information from several units and produce trends and patterns. Despite the final output of the IPR, the conduct of the meeting will generally remain the same. An IPR should occur as follows:

- a. Presentation of the IPR agenda by the Team Leader.
- b. Review of the next day's itinerary or upcoming unit itineraries.
- c. Discussion of any administrative data or requirements.
- d. Completion of the IPR Worksheet.

The best technique for completing the IPR Worksheet is to sketch out a worksheet matrix on butcher-chart paper with one objective per sheet. The Team Leader will designate a scribe to complete the worksheet by team or individual, by objective, and by information-gathering method (interviews, sensing sessions, etc.). The Team Leader will then call upon each team or individual to mention those items pertaining to that objective. For example, the Team Leader will begin by asking for interview results for Team A for Objective 1. Someone from Team A will state the information the team (or person) deems relevant while the scribe writes the information (in abbreviated form) on the butcher-chart paper. The process can stop for discussions and explanations as necessary. When the process is finished, the butcher-chart worksheet will be completed, and the team will have successfully shared the information. The person designated to develop the out-briefing slides will develop the briefing directly from this worksheet. Later, the Team Leader can transcribe the worksheet data onto a smaller electronic or

hand-written version of the worksheet for the inspection files or simply file away the butcher-chart version. A sample version of a completed IPR Worksheet for Undermanning of Individual Augmentees (IA) within JTF X-ray appears below in Figure 6-4.

Location(s): JTF X-Ray

Date: 20 Nov

Inspector	Objective 1	Objective 2	Objective 3
CDR Sailor	A gap in the IA personnel sourcing system - JTF X-RAY was manned at 93% of overall funded requirements; however, IA manning was at 72%.	J-1 and J-3 personnel properly trained - J-1 was not knowledgeable enough about the IA sourcing process to articulate clearly any gaps in the process. - J-3 confirmed findings with regard to J-1 knowledge of the IA sourcing process.	Readiness and workload impact - Decline in personnel readiness over the past three months.
MAJ Airman	- Disconnect between expansion of mission operational requirements and cross-check of personnel skill sets on board.		- Finding time to train is difficult due to the high operational tempo. - JTF X-ray enlisted leadership did not feel skill-set requirements are properly captured in the JMD.
MAJ Marine	- Personnel readiness has steadily declined from state Bravo to Charlie over past three months. - Not forecast to increase personnel readiness to state Bravo until February / March time frame.	- JTF X-ray J-1 suggested reviewing ECRC in Kuwait. - ECRC has a reputation of diverting personnel once they enter the AOR.	- Longer working hours and mission creep with fewer personnel on station.

Figure 6-4
IA IPR Worksheet

Note that this inspection only had three objectives and one team. The team completed this IPR Worksheet by team member and not separate teams, suggesting an IPR conducted at a unit for the purpose of developing an out-briefing.

e. Develop the out-briefing or complete the Trends Analysis Worksheet (see paragraphs four and five below).

- f. Final comments and guidance from the team.

The sample agenda outlined above can apply to all IPRs. The inspection team should develop a standard agenda the team can follow routinely without much preparation.

4. Developing the Out-Briefing. The out-briefing is the Joint IG team's way of providing some form of interim (or in some cases definitive) feedback on the results of a particular inspection. The team must recognize that the information presented during the out-briefing has not had the benefit of close analysis or extreme scrutiny. This detailed level of analysis occurs when developing and writing the Final Inspection Report. Therefore, the team must provide feedback that is informed, carefully written, and useful to the unit or the command. The team should not attempt to discuss issues or observations requiring further post-visit analysis.

- a. **Writing the Out-Briefing.** The Team Leader (or team member designated to develop the out-briefing) will draft bullet comments from the information captured on the IPR Worksheet during the IPR (or multiple IPRs if the visit lasts several days). The Team Leader must use discretion and not offer feedback on any issue the team has yet to analyze fully or validate. The Team Leader must also avoid attributing command names and individual names to the information offered. The only exception is for the slide depicting Good-News Observations, which may mention specific personnel, units, or commands. Finally, the summary slide should never state definitively that any unit or command's particular program is good or bad. In effect, the Joint IG team must remain neutral, even if the preponderance of out-briefing comments suggests the command is in compliance or not (see paragraph 5 in Section 5.5, Step 5: Train Up, for the out-briefing slide format).

- b. **Reviewing the Draft Out-Briefing.** The team will reserve time at the end of the IPR (or during the last IPR for extended visits) to review or build the out-brief. The team members will offer input and comments and make any necessary changes to the language. The Team Leader will then approve the out-briefing data for presentation.

- c. **Preparing the Out-Briefing for Presentation.** The Team Leader or designated scribe will develop the out-briefing slides using the established format. A laptop computer with a blank out-briefing shell works best. The Team Leader can use resources provided by the unit to print slides for a desk-side briefing or project the slides to a larger audience using a Proxima projector or other device. A sample out-briefing presentation is as follows:

Special Inspection of the IA Sourcing Process

Inspection Out-Briefing
JTF X-ray
20 November

Purpose

- To provide feedback to the Commander on the Joint IG's inspection of undermanning of Individual Augmentees (IA) within JFT X-ray.

Inspection Goal

- The goal of this inspection is to determine why JTF X-ray, Yankee and Zulu are consistently undermanned with regard to IA personnel.
-

Inspection Intent

- Conduct an inspection of JTF X-ray J-1 Joint manpower shop to determine cause of IA undermanning.
 - Conduct sensing sessions with senior officers and enlisted personnel.
 - Review manpower, mission, training, and readiness documents.
 - Specific results will remain with the unit or staff agency.
 - Conduct the inspection openly and discreetly.
 - *No surprises!*
-

Inspection Objectives

- Determine if there is a gap in the IA personnel sourcing system.
 - Determine if J-1 and J-3 personnel are properly trained.
 - Determine the readiness and workload impact due to the undermanning of IA billets.
-

Good News Observations

- JTF X-ray has a strong training program and has been very flexible and creative in meeting mission tasking.
 - Senior enlisted leadership is fully engaged in mission training and has requested SME training from other JTFs as required based on new mission-tasking orders.
-

Undermanning of Individual Augmentees (IA)

Observations

- All leaders are fully engaged in maintaining unit readiness and training.
 - Personnel are working extremely long hours to maintain mission readiness.
 - Joint IG team will require a visit to the ECRC to determine their manning diversion priorities.
-

Undermanning of Individual Augmentees (IA)

Documents Reviewed

- JTF X-ray not familiar with JP 1-0 and did not fully understand the IA Sourcing Process.
 - JTF X-ray JMD reviewed for skill-set accuracy. Team noted lack of skill sets required for convoy ops, support fire teams, and security watch details. JMD execution is not completed in a timely manner.
 - JTF X-ray personnel and mission readiness reports were reviewed for historical trends, accuracy, and timeliness and found a steady decline in IA personnel readiness over the past three months. All reports were accurate and timely.
-

Undermanning of Individual Augmentees (IA)

Interviews and Sensing Sessions

- Officer and senior leadership are aware of the gapped IA critical skill billets with the JTF and are working diligently to maintain mission readiness despite the 18% manning gap in IA billets.
 - Gapped IA billets add additional duty hours and stress due to optemp requirements.
-

Summary

- Strong evidence exists that there are critical skill gaps due to the undermanning fo IA personnel, forcing additional workload onto other personnel.
 - Require review of other JTFs within the AOR before determining course(s) of action.
 - Thank you for the support!
-

5. Developing Trends and Patterns. The Team Leader will have a designated scribe create a Trends Analysis Sheet (See Figure 6-5) format on butcher-block paper so team members can see the information. The Team Leader will ask the team members to nominate any trends that have appeared during the course of the inspection. The scribe will write the nominated trend in the appropriate column, and the team will address this trend with each unit or agency inspected to date. This process will either validate or invalidate the trend. If more than 50 percent of the inspected units do not confirm the nominated trend, then the trend is not valid. If the team developed trends during a previous IPR (or IPRs), then the team should re-validate those trends with the units covered during the current IPR. Some trends established in previous IPRs may fall away or become invalid as the inspection progresses. A sample Trends Analysis Sheet for an Individual Augmentation sourcing process inspection appears below.

SAMPLE -TRENDS ANALYSIS

TREND	JTF X-ray	JTF Yankee	JTF Zulu
1. JTF J-1s understand IA sourcing process	J-1 lacked detailed knowledge of IA sourcing process	J-1 well versed in IA sourcing process	J-1 had strong background in IA sourcing process
2. Increased workload due to gapped IA billets	Officer and enlisted leadership well aware of increased workload due to gapped critical IA billets	Officer and enlisted leadership well aware of increased workload due to gapped critical IA billets	Indoctrination course incorporated training to cover critical gapped IA billets lowering the stress on the JTF personnel
3. JTF J-3s understand Joint manpower requirements	Limited knowledge	Excellent understanding	Excellent understanding
4. Morale is good	Poor morale due to stress of additional duties and working hours	Good morale	Excellent morale due to well planned spreading of workload among personnel

**Figure 6-5
IA Trends Analysis**

Section 6.3

Execution Phase

Step 9. Update the Commander

1. **Updating the Commander.** The Joint commander who directed the inspection may request a mid-inspection update from the inspection team. This update should be part of the inspection timeline. If the commander does not request an update, the inspection team should anticipate that the commander may change his or her mind. In any case, the Team Leader or a designated member of the inspection team should build and maintain an update briefing for a scheduled or unscheduled presentation to the commander. The physical output of this step is the update briefing for the commander.

2. **Information Source.** Since the inspection team cannot pause in the middle of the actual inspection to analyze results and develop findings, the inspection team must rely on the trends or patterns captured during the periodic IPRs (normally conducted every third or fourth inspection visit). The team captured this information on the Trends Analysis Worksheet, so the inspection team should update the commander with the most recent version of these trends. The team should resist the temptation to develop "interim" finding statements that may not hold true when the team writes the Final Report.

3. **Briefing Outline.** Since the commander may not recall the details of the inspection concept, the inspection team should design the briefing to remind the commander of the inspection plan and to provide the commander with the most current trends. A recommended slide outline (or agenda) is as follows:

- (1) Purpose of the Briefing
- (2) Inspection Goal (or Purpose)
- (3) Inspection Objectives
- (4) Task Organization
- (5) Inspection Concept
- (6) List of units or agencies that the team (or teams) has visited followed by a list of the remaining units or agencies to visit
- (7) Inspection Timeline
- (8) Trends (bullets taken directly from the Trends Analysis Sheet)

Section 6.4

Execution Phase

Step 10. Analyze Results and Cross-Walk

1. **Drafting the Final Report.** Analyzing results means the Team Leader must organize the inspection team to write a draft version of the Final Report, which is the only physical output of this step. Before beginning this step, all visits to units or agencies must be complete, and the Trip Reports for each visit must be finished. The Team Leader must develop a plan for writing the draft version of the Final Report, assigning writing responsibilities to each team member and establishing a writing schedule or timeline. The timeline must give the team members time to analyze the results, write their findings, and conduct cross-walking as necessary. The Final Report must also follow the format prescribed by the Team Leader. The reason the team writes a draft version of the Final Report as part of the Execution Phase is that cross-walking activities may result in gathering additional information. During the Completion Phase, all information-gathering activities cease.

2. **Cross-walking.** Cross-walking is the process of verifying and validating inspection results. In other words, an IG inspector may need to check with other sources or agencies to verify or validate what he or she saw, read, or heard during the conduct of the inspection. Cross-walking may take a Joint IG up the chain (vertically) or across command lines (horizontally). In most cases, cross-walking is nothing more than a phone call to someone who might offer greater insight into a particular issue or who might verify what the inspector read, saw, or was told is accurate. Cross-walking occurs throughout the report-writing process as required, but Joint IGs must always be sensitive to chains (and lines) of command when conducting cross-walking.

3. **Final Report Format.** Every unit or command will have different requirements or SOPs for staff products and reports. Joint IG inspection reports should follow unit or command guidelines as closely as possible to ensure compliance with the local SOP. However, final inspection reports are not brief memorandums a few pages in length. Final Reports are normally self-contained booklets containing chapters which outline each inspection objective's findings. The recommended format for a final inspection report is as follows:

- a. Table of Contents
- b. Guidance on the release of Joint IG information
- c. Executive Summary (perhaps the most widely read portion of the report!)
- d. Separate chapters on the inspection Background and Methodology
- e. Chapters for each Objective with the findings presented by Sub-Task
- f. Summary of the Recommendations (usually separated by proponent)

g. Appendices:

- (1) References
- (2) Inspection Directive (signed copy)
- (3) List of units or commands visited
- (4) Interview and Sensing-Session questions

4. **Task Organizing the Inspection Team.** The Team Leader must organize the team to write the Final Report and assign specific responsibilities to each team member. The previous task organization (if using separate teams) no longer applies at this point. The Team Leader should organize the team as follows:

a. **Overseer of the Writing Process.** This person is normally the Team Leader, who is usually not responsible for writing any portion of the report. The Team Leader must remain as neutral as possible during the findings-development process so he or she can effectively judge each chapter's logical sufficiency.

b. **Writers for each Objective Chapter.** The team members assigned to write the main chapter objectives are normally the Joint IGs and not the Temporary Assistant IGs (TAIGs). TAIGs may write a chapter if the information or data is extremely technical in nature and may prove too challenging for a Joint IG. Joint IGs write the objective chapters because they are trained to analyze the information in a particular way, which will ensure a consistent approach to the information the team gathered.

c. **Chapter-Review Committee.** The Team Leader will establish a Chapter-Review Committee to review all chapters for logical sufficiency and general correctness. Logical sufficiency is simply a clearly stated thesis (a finding statement) derived from the sub-task and supported effectively by clearly presented evidence (a discussion paragraph) with a further supporting analysis (root cause) that determines how to change the nature of the thesis (recommendations). A simplified "backward check" for logical sufficiency is as follows:

Will the recommendations, when implemented, eliminate the root cause of the problem and thereby change the nature of the finding? If the answer is yes, then you have logical sufficiency.

The purpose of this detailed review is to ensure the team discovers all problems with the chapters before releasing the results to the proponents, the commander, and the command. The Chapter-Review Committee usually consists of the Team Leader and two or more of the TAIGs.

d. **Writer for the Background and Methodology Chapters.** The team member who writes these two chapters is normally the Team Deputy. Much of this information will come directly from the initial planning documents such as the Detailed Inspection Plan.

e. **Final Editor and Reviewer.** The Team Leader usually takes this assignment; however, the Team Leader may select someone from within the team who has excellent grammar skills and writing abilities. The purpose of this assignment is to ensure comprehensibility and readability.

5. Writing an Objective Chapter. How does a Joint IG write a chapter for an objective?

This process can be very challenging and in some cases, difficult. The writer is faced with what seems like a mountain of information to sort, read, and analyze. The writer must first begin by reviewing the chapter format established by the Team Leader. At a minimum, the chapter format will have the Joint IG writer developing no less than one finding statement per Sub-Task. Some Sub-Tasks may have two or three findings. These findings sections should follow the recommended format, which this section will explain in detail later. This guide outlines a **nine-step process** any IG inspector can use to analyze results and develop findings for a particular Sub-Task. After developing the findings section for each Sub-Task, organize the chapter follows:

- a. Objective 1:
 - (1) Sub-Task 1:
 - (a) Finding 1 (write out the entire five-paragraph findings section under each finding heading)
 - (b) Finding 2
 - (2) Sub-Task 2:
 - (a) Finding 1
 - (b) Finding 2
 - (3) Sub-Task 3:
 - (a) Finding

6. Nine-Step Process for Developing a Finding Statement. The nine-step process outlined below is designed for IG writers to develop one finding statement (and findings section) at a time. Repeat this process for each Sub-Task. If the inspection objective has five Sub-Tasks, then follow the first seven steps of this process five different times before completing steps eight and nine. Once the writer has become familiar with this process, the development of the finding statements and sections will become much easier. The nine-step process is as follows:

a. **Step 1: Gather the Tools.** Print copies of all Trip Reports the team produced for each visit to a unit or agency. The Trip Reports will serve as the primary-source documents for the chapter. Next, craft a word-processing template of the chapter you will write using the established format. This template will allow you to move quickly through the organization and writing process. You can simply insert each completed findings sections into its appropriate place within the chapter before writing the next one. Have all key references pertaining to the inspection as well as a copy of The Joint IG Inspections Guide. Lastly, gather highlighters of different colors to color-code the information on the Trip Reports as you read through them.

b. **Step 2: Develop a Writing Schedule.** Craft a calendar plan identifying specific days to work on a particular Sub-Task or portion of the chapter. Tailor this schedule to your abilities -- but be realistic! Don't develop a fast-paced schedule if you don't think you can adhere to it. Next, review the writing schedule to ensure it meets the overall report-writing timeline established by the Team Leader. Be sure to set aside time to review the draft. Once the schedule is developed, stick to it!

c. **Step 3: Organize Your Sources.** Gather the Trip Reports and write bold headings at the top of each one using a colored pen or marker to distinguish easily and quickly one from the other. Remember: You will be juggling several different Trip Reports as you write your chapter, so developing a system allowing you to find your

references quickly is essential. Place the Trip Reports in folders or develop some other system to ensure ease of access and organization.

d. **Step 4: Review and Study Your Sources.** This phase of the writing process is normally called pre-writing. Go through each Trip Report and use the different colored markers to highlight the information for each of your Sub-Tasks. Highlight the information one Sub-Task at a time since you will write one findings section at a time. Go back and read all of the information pertaining to the Sub-Task you plan to write. Absorb and try to understand the varying types of information without attempting to analyze or categorize the information. Let your mind wander freely! This process will result in a draft finding statement (or statements) which you should capture on paper.

e. **Step 5: Develop Tools to Collect and Analyze Your Information.** After absorbing the information and crafting a draft finding statement (or statements), develop a tool to help you organize your thoughts and the information gathered. Use a blank Trends Analysis Sheet or a similar type of matrix to identify and lay out the common bits of information gleaned from the Trip Reports. Write the draft finding statement in the left-side column and then verify its accuracy by each individual Trip Report. If the preponderance of information from the Trip Reports supports the draft finding statement, then the statement is accurate. How you collect and organize the information is up to you, but do not allow yourself to become bogged down by smaller bits of information. Stay focused on the big picture! Some information may have no context or applicability and may fall away (these bits of information are known as **orphans**). Conduct **cross-walking** as necessary for additional information or for clarification. Call or visit those individuals or agencies you think can help you validate inspection information.

f. **Step 6: Develop Your Finding Statements.** Refine the language of the draft finding statement (or statements) as necessary. The finding statement is a single, well-focused, well-structured sentence capturing the true essence of the finding. This sentence must be able to stand alone. You will base your finding statement (or statements) on the preponderance of information you gather about a particular Sub-Task. For example, if 65 percent of the data collected leans toward a widespread finding that JTFs in your AOR have gapped IA billets, then your finding will state that fact. Address the other 35 percent who are having success when writing the Inspection Results portion for that findings section. Here is an example of a finding statement:

All JTFs in the COCOM's AOR have significant gaps in critical skill IA billets.

g. **Step 7: Write Your Findings Sections.** Follow the recommended findings-section format when writing all of the information that applies to the finding. The format is:

- (1) Finding Statement
- (2) Standard
- (3) Inspection Results (Discussion)
- (4) Root Cause
- (5) Recommendation(s)

Each Sub-Task will have no less than one findings section; some Sub-Tasks may have two or three finding statements and sections. Be certain to include both positive findings and not just negative. Good-news stories are always welcome. Include with your finding

statement the effect or potential effect of this finding. Effects are the impacts or answer to the question “so what” and makes taking action on the Recommendation worthwhile. In paragraph two, **Standard**, write, verbatim, the entire standard for that finding from the original source. Do not paraphrase the text. In paragraph three, **Inspection Results**, address each and every point to support the finding. For paragraph four, **Root Cause**, follow the Root Cause Analysis Model to describe the reasons for compliance or non-compliance (don't know, can't comply, and won't comply). Finally, in paragraph five, **Recommendation**, ensure each recommendation is detailed and identifies the person or staff agency who can fix the problem.

h. **Step 8: Complete the Chapter.** Compile all of the completed findings sections into one document using the established chapter format. Read and re-read the chapter several times to ensure consistency and to avoid needless redundancy. Read the chapter out loud to help eliminate grammar errors or extraordinarily long sentences.

i. **Step 9: Submit the Chapter for Peer and Committee Review.** Let someone else read the draft chapter and point out obvious errors or inconsistencies. Make necessary adjustments to the draft and print a clean copy. Give the clean copy to the Team Leader for Committee Review. The Team Leader will arrange a time to meet with the committee to answer questions or address problem areas (See Figure 6-6) with the text (a type of "murder board"). Make necessary changes and submit a clean copy to the Team Leader for a final grammar and format review. A graphic representation of the Committee Review process follows:

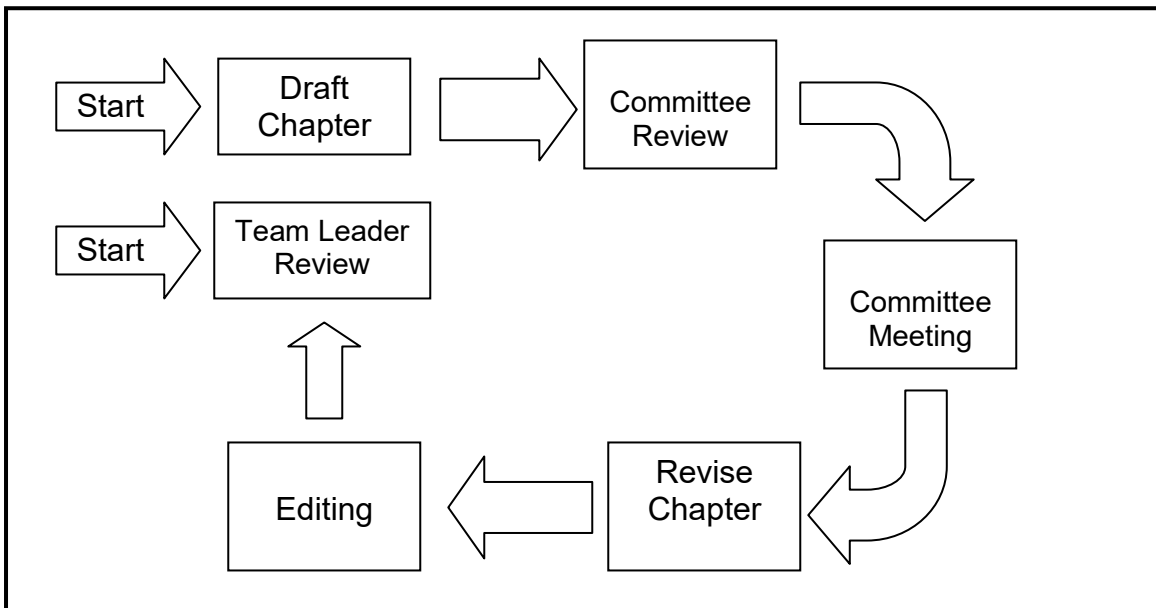

Figure 6-6
Peer and Committee Review Process

7. **Practical Example of the Nine-Step Process.** You have just finished an inspection of JTFs X-ray, Yankee, and Zulu concerning under-manning of Individual Augmentation (IA) billets. You are the team member assigned to write the chapter for Objective 3, which reads as follows:

Objective 3. Determine readiness and workload impact due to the undermanning of IA billets.

Your team developed two Sub-Tasks for this objective, and you are about to write the findings section for Sub-Task 3.1, which reads as follows:

Sub-Task 3.1. *Conduct sensing sessions* to determine the impact on readiness with regard to the undermanning of funded IA billets.

a. **Gather the Tools.** Begin by gathering copies of all Trip Reports printed and ensure each one is stapled together. Develop a word-processing template of the chapter and save it on the computer. Check to ensure the template follows the Team Leader's format precisely and type findings sections directly into this template -- one section at a time. Gather four highlighters of different colors since there are four Sub-Tasks to write.

b. **Develop a Writing Schedule.** Consult the Team Leader's overall report-writing timeline and develop a reasonable writing schedule that fits well within the Team Leader's plan. The writing schedule looks as follows:

- 24-26 November: Write Sub-Task 3.1
- 1-3 December: Write Sub-Task 3.2
- 4-8 December: Write Sub-Task 3.3
- 8-10 December: Write Sub-Task 3.4
- 10-12 December: Finish and Proofread the Chapter

c. **Organize Your Sources.** Organize the Trip Reports by writing the name of the applicable unit or agency boldly in red pen at the top of each Trip Report. Stack the Trip Reports in a staggered fashion so only the headings show. This technique allows you to pull a Trip Report from the stack quickly and then replace it without becoming disorganized or scattering the other Trip Reports.

d. **Review and Study Your Sources.** Review each Trip Report for those observation paragraphs that pertain to Sub-Task 3.1. Highlight the Sub-Task number at the top of the observation and read through the paragraph, highlighting the sentences that apply to Sub-Task 3.1. Complete this process for all Trip Reports using (for example) a yellow highlighter for information pertaining only to Sub-Task 3.1. The information you discovered in the Trip Reports follows (the information is underlined and not highlighted in these cases):

(1) **JTF X-ray Trip Report. Observation 1** (Sub-Tasks 3.1). **Sensing Session with Officers and Senior NCOs.** (Eight officers and four senior enlisted, 15 NCOs) Both officer and enlisted personnel noted increased training demand on all units due to being undermanned. Spend too much time training with little down time between missions and training. Morale is lower than usual because of lack of down time. Senior Enlisted personnel are trying to be innovative in developing ways to maintain readiness

with the IA gap, but it is difficult. Senior enlisted personnel spending too much time training personnel and are falling behind in their administrative requirements. Senior enlisted personnel spend too much time outside the wire and don't have time for being leaders inside the wire. Officers and senior enlisted have not requested the assistance of other JTFs in the AOR. At least two IA billets in each department are gapped. Readiness officer was in the sensing session and noted a decline in personnel readiness over the past three months and a decrease from state Bravo to Charlie.

(2) **JTF Yankee Trip Report: Observation 2** (Sub-Tasks 3.1). **Sensing Session with Officers and NCOs**. (Five officers and six senior enlisted, 19 NCOs) Officer and enlisted leadership were well aware of increased workload due to gapped critical IA billets; however, a strong training program has helped alleviate most of the strains of IA under-manning. On average, only one IA billet gapped per department. JTF Yankee has not had an increase in mission requirements or skill-set mismatch. Only minor changes to watch standing have been incorporated to lower the impact of fewer IA personnel. Personnel are standing more watches and spending more time outside the wire. Senior enlisted embracing the leadership challenge by exercising intrusive leadership techniques and stressing small-unit leadership among the NCOs. Officers have empowered senior enlisted and NCOs to think innovatively to reduce non-mission-oriented workload. Personnel readiness remains at state Bravo.

(3) **JTF Zulu Trip Report: Observation 2** (Sub-Tasks 3.1). **Sensing Session with Officers and NCOs**. (Six officers and three senior enlisted, 12 NCOs) Indoctrination course incorporated training to cover critical gapped IA billets lowering the stress on the JTF personnel. On average, only one IA billet gapped per department. Mission tasking has remained consistent, and there is an expectation that IA shortfalls will end by January. Great indoctrination training as soon as personnel arrive on station; they spend the first week learning the AOR and mission and receiving in-depth training in multiple skill sets that IA personnel typically cover such as all convoy operations positions (best practice for other JTFs in AOR). The senior leadership emphasizes and expects small-unit leadership. Personnel readiness remains at state Bravo.

Once you have highlighted the information, go back to the applicable Trip Reports and read only the highlighted portions. Read this information in a leisurely fashion to absorb and understand all aspects of the data the inspection team gathered concerning Sub-Task 3.1 (the information presented for this example is small in scope by design). Read the information and allow your mind to wander freely. You begin to see some patterns developing. Note that the IA sourcing process is not always well understood, and there is a disparity between manning levels among the JTFs. You now have a draft finding statement.

e. **Develop Tools to Collect and Analyze Your Information**. Once you have absorbed the information highlighted in yellow in the applicable Trip Reports, use a matrix resembling the Trends Analysis Sheet (See Figure 6-7) to lay out the information. Ensure you can support your mental assessment of the Individual Augmentation Sourcing Process Inspection by transcribing the information onto the matrix to depict graphically which way the preponderance of evidence truly falls. Your completed matrix, with your first-draft finding statements, follows:

Findings	JTF- X-ray	JTF Yankee	JTF Zulu
JTF J-1 personnel understand the IA Sourcing Process	- J-1 lacked detailed knowledge of IA sourcing process - J-1 had limited knowledge of manpower requirements determination	- J-1 well versed in IA sourcing process - J-1 well versed in manpower requirements determination	- J-1 had strong background in IA sourcing process - J-1 had excellent understanding of manpower requirements determination
IA Manning Levels are not at 100%	- 72% of IA manning requirement - state Charlie	- 79% of IA Manning requirement - State Bravo	- 82% of IA manning requirements - State Bravo

**Figure 6-7
Findings Matrix**

You developed two draft finding statements, which you wrote in the left-hand column. However, you begin to think the bottom one is an issue you can discuss in the findings section for the top statement. The evidence suggests the lack of Joint manpower knowledge is a direct reflection on how well the JTF is manned based on IA requirements in the JMD. You decide to conduct a **cross-walk** to confirm what your inspection team learned at JTF X-ray. Your team contacts the ECRC via phone conference to determine their IA manning divert policy and priority. The ECRC Commanding Officer informs your team that JTF X-ray has not requested any additional IA personnel; the JTF X-ray JMD does not reflect any new skill set requirements; and, therefore, JTF X-ray is considered a low IA manning priority. The ECRC Commanding Officer highly suggests that JTF X-ray J-1 contact them immediately for JMD review/ update and new IA manning requirement skill sets based on additional mission tasking.

f. **Develop Your Finding Statements.** You decide to develop only one finding statement for Sub-Task 3.1. Write out a refined version of the finding statement and scrutinize it carefully, ensuring the sentence captures what needs to be said and that it can stand alone. The finding statement is below:

Most JTF J-1 personnel are properly trained and are well versed in Joint Manpower Requirements and are operating within the Individual Augmentation (IA) Sourcing Process.

g. **Write Your Findings Section.** Using the recommended five-part format for the findings section, begin drafting your findings section for Sub-Task 3.1. Insert the finding statement you developed during the previous step into the first paragraph. Next, find the IA Sourcing Process in Joint Publication 1-0 and quote the process verbatim in the second paragraph. Write the Inspection Results portion and explain how you arrived at your finding. Ensure you address the fact that not all JTF J-1s require additional training. Keep in mind you cannot attribute unit names or individual names to the information gathered. The findings section must be fully redacted for all attribution. Next, follow the Root Cause Analysis Model and ask yourself the questions posed by the model. Go through the entire model to capture all possible root causes. In this case, you determine the JTF J-1s are well versed in the IA sourcing process; however, the

experience level of the J-1 is a key indicator of process knowledge. Base your recommendation on a solution that will ensure JTF J-1s receive requisite training prior to deployment in Joint arena. The completed findings section appears as follows:

(1) **Finding Statement.** Most JTF J-1 personnel are properly trained and well versed in Joint Manpower Requirements and are operating within the Individual Augmentation (IA) Sourcing Process.

(2) **Standard.** Joint Publication 1-0, Personnel Support to Joint Operations, Appendix F, Individual Augmentation Planning and Procedures, Paragraph 3, Rotation Planning:

“Careful management of troop rotation is critical to the sustainability of operations. The J-1 must track and coordinate with Service components to ensure timely rotations. To strengthen the support link, message traffic regarding individual augmentation actions should be addressed to all supporting combatant commands, Services and/or Service components HQ (operations and personnel offices), and Joint Staff and DOD Agencies. The J-1 must also ensure that individual rotations are properly monitored, so that deploying personnel receive the maximum advance notification possible. Every effort should be made to ensure that individuals receive a minimum of 30 days notification prior to deployment as a rotational replacement.”

(3) **Inspection Results.** The Inspection Team determined that two of three JTF J-1s fully understood the Individual Augmentation Sourcing Process and how to work IA manpower and manning issues in accordance with Joint Publication (JP) 1-0. One JTF J-1 was not familiar with JP 1-0 and was not fully trained in Joint operations prior to receiving orders to the JTF J-1 billet. The lack of formal training left the JTF J-1 unaware of reporting criteria and interpretation of the Joint Manning Document. (Note: The Inspection Results portion is normally two to three paragraphs in length. Since this example only uses the results gleaned from three units, this section contains only one brief discussion paragraph).

(4) **Root Cause.** (Don't Know) Some JTF J-1 personnel were not familiar with the inner-workings of the Individual Augmentation Sourcing Process, Joint Manning Document review and update, or skill-set requirements determination process.

(5) **Recommendation.** The Joint IG recommends that all Service components review the training syllabus for developing J-1 personnel, ensuring comprehensive knowledge of IA planning and procedures in accordance with JP 1-0, Joint Manning Document review and update procedures, and skill-set requirements determination.

You have decided to name the Joint Staff J-1 as the proponent, or agency that can fix this problem. The Joint Staff J-1 is central to the IA sourcing process and has a clear understanding of JTF J-1 knowledge, skills, and abilities and is in a position to ensure Service Components adhere to the training requirements. After you type the findings section into your electronic template, ensure the document has the correct footer at the bottom now that you have added Joint IG information to the document. The footer is as follows (see Section 4.4, Step 16, for further information on footers): FOR OFFICIAL USE ONLY.

h. **Complete the Chapter.** You have now finished writing all four findings sections. You compile all four sections into your electronic template and ensure the format is correct. You print a copy of your completed chapter and read it out loud to ensure that the sentences work well and no obvious grammar errors are apparent. After making some adjustments to the text, you decide to ask another team member to read through the chapter and point out any problems.

i. **Submit the Chapter for Peer and Committee Review.** Your peer reviewer gives you some excellent feedback, so you revise portions of the chapter one more time. Next, you submit the chapter to the Team Leader for review by the committee. The Team Leader takes your chapter, makes several copies of it, and distributes those copies to the other members of the committee (in this case one augmentee). Once the committee reads through the chapter, they meet and discuss your work privately. They evaluate the logical sufficiency and accuracy of each findings section within your chapter by using the following checklist:

(1) **Finding Statement.** Does the Finding Statement succinctly and clearly capture the nature of the issue or problem?

- Yes
- No. The Finding Statement is too vague and does not stand alone.
- Other _____

(2) **Standard.** Are the standards quoted in this paragraph the correct or relevant standards?

- Yes
- Yes, but the writer misquoted the original text.
- Yes, but the writer failed to identify the source down to the paragraph number and page number.
- Yes, but the writer only paraphrased the standard and did not quote the standard verbatim from the original source.
- No. The standards are incomplete.
- No. Other _____

(3) **Inspection Results.** Does this paragraph (or paragraphs) effectively explain the results and types of information that led the writer to develop the Finding Statement listed above?

- Yes
- Yes, but the discussion does not mention any of the good-news stories that arose from this particular issue.
- No. The discussion does not address sufficiently the issue(s) or point(s) identified in the Finding Statement and requires further expansion.
- No. Some points made in the Inspection Results paragraph do not support the Finding Statement (these points may be **orphans**, or bits of information that do not relate to the bigger picture and which should fall away).
- No. The discussion does not help to quantify the scope of the issue or point made in the Finding Statement (most units, a majority of the units, many of the units, some of the units, and so on).
- No. Other _____

(4) **Root Cause.** Does this paragraph capture all of the reasons for compliance or non-compliance?

- Yes
- No. This paragraph just repeats the Finding Statement and does not explain the reason (the "why") for compliance or non-compliance.
- No. The root cause is completely off the mark.
- No. Fixing the root cause as stated would not correct the problem.
- No. The root cause as stated is only a symptom of the real root cause and not the actual root cause itself.
- No. Other _____

(5) **Recommendation(s).** Does the recommendation fix the problem as outlined in the Finding Statement and captured by the Root Cause?

- Yes
- Yes, but the recommendation fails to name the appropriate proponent (a person or staff agency best suited to fix the problem).
- No. Other _____

Overall comments:

- Are the Finding Statement and Recommendation paragraphs logically sufficient?
- Do the Finding Statement and Recommendation paragraphs share a logical connection?
- Does the Recommendation fix the problem or issue outlined in the Finding Statement?
- Does the chapter require a legal review before final approval?

Once the committee agrees on the adjustments that you should make to the chapter, the Team Leader sets a time for you and the committee to meet to discuss the changes (somewhat like a "murder board"). After the meeting, you return to your desk and make the corrections to the chapter. Next, you submit a clean copy to the Team Leader for a final grammar and format review. Once the Team Leader approves the final product, your chapter is finished and ready for inclusion in the draft version of the Final Report.

8. The Final Result. The final result of this step of the Execution Phase, the physical output, is a draft version of the Final Report. The Team Leader will compile the approved chapters into the draft Final Report and use that draft to develop a slide presentation for the proponents and the commander. The inspection team must consider the report a draft at this stage because the commander has not yet approved the results.

Section 6.5

Execution Phase

Step 11. Out-Brief the Proponent

1. **Identifying the Proponent.** The proponents are the individuals or staff agencies identified in your recommendation paragraphs to fix the identified problems. Each recommendation must name at least one proponent. Joint IGs must ensure the proponent identified in the recommendation is the correct one to fix the problem. The Joint IG should always call first and, without revealing information about the inspection, determine if that person or staff agency is the right one to execute the proposed solution. If the recommended solution concerns a particular standard or regulation, the Joint IG should determine what person or staff agency is the proponent for that standard or regulation. For example, if the Chairman of the Joints Chiefs Of Staff (CJCS) is the proponent for the Individual Augmentation regulations or standards you are addressing, then the Joint Staff J-1 is the proponent best suited to adjust or change that standard or regulation. However, if the problem can be solved at your level but still concerns that standard or regulation, the staff agency at your level that is responsible for the personnel function (the J-1 at the COCOM, for instance) should be listed as the proponent. The counterpart relationship all Joint personnel agencies have with the COCOM J-1, and the regulations governed by the CJCS J-1, means they share a common responsibility for those regulations. However, CJSC J-1 is the only staff agency that can physically change or revise the policy.

2. **Out-Briefing the Proponent.** Before the commander sees the results of the inspection, the Joint IG team should extend a professional courtesy to those individuals or staff agencies listed to fix the variety of issues the IG team recommended. The Team Leader should schedule a briefing with the head of the staff agency or the individual involved and share the findings and recommendations pertaining only to that person or staff agency. The Team Leader does not have to share the results of the entire inspection with each proponent. The slide briefing, the only physical output of this step, should cover the following areas:

- a. Inspection Background and Concept (slides on the Inspection Purpose, Inspection Objectives, and Inspection Concept)
- b. Inspection Methodology (slides on the overall Inspection Approach, Task Organization, and units or agencies visited)
- c. Results of a Legal Review (if a legal review was necessary)
- d. Findings by Objective and Sub-Task with Recommendations (one slide for each finding listing the Inspection Objective, Sub-Task, Finding Statement, and Recommendation) [**Note:** Show only those slides pertaining to the proponent you are briefing.]

If a face-to-face briefing is not possible, then a telephone call to the proponent covering all of this information verbally is acceptable.

3. Purpose of the Briefing. The purpose of the briefing is to inform the proponent about the recommendations you will make to the commander which, once approved, will require that proponent to take corrective action. The briefing is an information briefing only and does not require the concurrence of the proponent. The proponent may tell the Team Leader the Joint IG is naming the wrong proponent to fix a particular problem, which may result in a change to the draft version of the Final Report. However, advance research on the correct proponent by the Joint IG team members should preclude this problem. Finally, the proponent does not have to agree with the findings or recommendations. The proponent may offer other options, which the Joint IG can use to refine the recommendations, or simply disagree with some or all of the findings and recommendations. A proponent's disagreement does not mean the Team Leader deletes a finding (or findings) from the report. The Team Leader will note the proponent's non-concurrence and inform the commander during the commander's out-briefing. Once all proponent out-briefings are complete, the Joint IG inspection team is ready to transition to the Completion Phase of the Inspections Process and out-brief the commander.

Figure 6-8 shows the steps with the associated completed items.

Step 7	Step 8	Step 9	Step 10	Step 11
Trip Report	Trends Analysis	Update Briefing	Draft Final Report	Inspection Results Briefing
	Unit(s) Out Briefing			

**Figure 6-8
Execution Phase and Outputs**

Chapter 7

Completion Phase

Section 7.1 Step 12: Out-brief the Commander

Section 7.2 Step 13: Taskers

Section 7.3 Step 14: Finalize Report

Section 7.4 Step 15: Handoff

Section 7.5 Step 16: Distribute the Report

Section 7.6 Step 17: Schedule a Follow-up Inspection

Chapter 7

Completion Phase

1. **Purpose.** This section discusses the Completion Phase of the Inspections Process and the six steps included in that phase.

2. **The Completion Phase.** The Completion Phase (See Figure 7-1) of the Inspections Process puts the finishing touches on the Final Report and includes those steps necessary to ensure the designated components fix the recommended solutions. The Completion Phase has six discrete steps, but some of these steps may occur simultaneously after the commander approves the inspection results. The six steps of the Completion Phase are as follows:

- a. Out-Brief the Commander
- b. Issue Taskers
- c. Finalize the Report
- d. Handoff
- e. Distribute the Final Report
- f. Schedule a Follow-Up Inspection

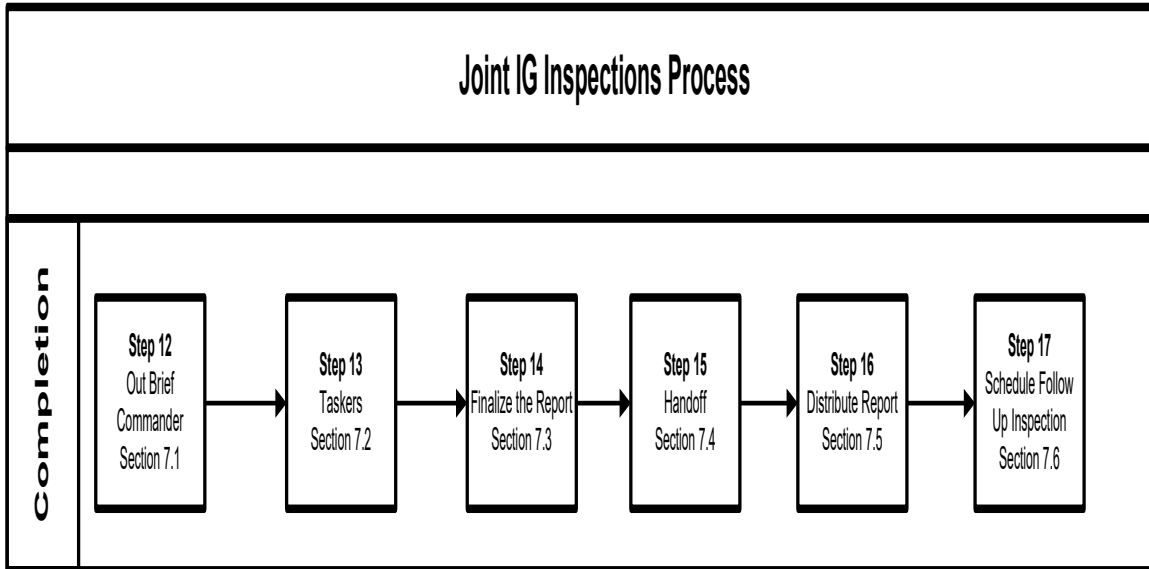

Figure 7-1
Completion Phase

Section 7.1

Completion Phase

Step 12. Out-Brief the Commander

1. **Out-Briefing the Commander.** The out-brief to the Joint commander should be a formal event designed to gain the commander's approval of the final inspection report. The Team Leader should present a well-prepared briefing to the commander and have on hand the draft Final Report in case the commander requests a copy for further review. The Team Leader should invite all of the proponents to the briefing and any other staff-agency heads who might be interested in the inspection results. In addition, the Chief of Staff is normally present at these briefings.

2. **Contents of the Briefing.** The briefing is a decision briefing that, once presented, will request the commander's approval or disapproval. The briefing will be similar to the version the Team Leader presented to the proponents. The greatest difference will be that the briefing will include all findings and recommendations. The briefing, the only physical output of this step, should cover the following areas:

- a. Inspection Background and Concept (slides on the Inspection Purpose, Inspection Objectives, and Inspection Concept)
- b. Inspection Methodology (slides on the overall Inspection Approach, Task Organization, and units or agencies visited)
- c. Results of a Legal Review (if a legal review was necessary)
- d. All inspection findings by Objective and Sub-Task with Recommendations (one slide for each finding listing the Inspection Objective, the Sub-Task, Finding Statement, and Recommendation)
- e. Results of the proponent out-briefings (to include any non-concurrence issues that the proponents raised)
- f. Timeline for completion and distribution of the Final Report
- g. Request for the commander's approval or additional guidance

3. **Commander's Approval.** In most cases, the commander will approve the inspection results based upon a review of the Finding Statements and Recommendations. However, the commander may direct some changes or adjustments to the Final Report before he or she will concur with the inspection results. For example, the commander may opt to change findings that are not adequately substantiated or are factually incorrect. The commander may also choose to withhold his or her approval pending a detailed review of the entire draft version of the Final Report. In any case, the inspection team cannot proceed with the remaining steps of the Completion Phase until the commander approves the report. Once approved, the report is no longer a draft document, and the Inspection Directive expires.

Section 7.2

Completion Phase Step 13. Taskers

1. **Issuing Taskers.** The individuals or staff agencies identified in each recommendation will receive taskers initiating required actions to fix the problem. In most cases, the proponents begin work to fix the problem areas immediately after the Joint IG team briefs them as part of Step 11 in the Execution Phase. Upon the report's approval, the Chief of Staff, the Secretary to the Joint Staff (SJS), or the operations staff section will usually issue the taskers and then monitor their completion.

2. **Joint IG's Role in Taskers.** Joint IG's role is to monitor the assignment and completion of taskers. Joint IG is not a tasking authority and should never assume a supervisory role when monitoring the taskers. If the Joint IG team feels a proponent is not correcting a problem within a reasonable amount of time or within the parameters of the recommendation, the Joint IG team can raise that concern with the appropriate tasking authority. Joint IG team should always be prepared to work with the staff agencies or individuals tasked to help them solve or fix the problem(s).

Section 7.3

Completion Phase

Step 14. Finalize the Report

1. **Finalizing the Written Report.** The inspection team should make any necessary adjustments to the Final Report immediately following the briefing to the commander. The commander may have directed some changes to the wording of one or more finding statements or adjusted the proponents. The Team Leader or a designated member of the team should conduct one final edit of the report ensuring accuracy, consistency, and general grammatical correctness. This final edit should further ensure the report is completely redacted (does not name names or mention commands) of all attribution. Confidentiality is crucial.

Remember: The information contained in the report is what is important and not the sources of the information.

2. **Commander's Cover Letter.** The inspection team must develop a cover letter for signature by the Joint commander approving the report's findings and recommendations. This letter becomes the first page of the Final Report and should include the commander's letterhead, office symbol, an approval statement, and the commander's signature block with signature. This cover letter is the only physical output of this step.

3. **Submit the Final Report to the Joint Commander.** Submit a copy of the Final Report and a copy of the cover letter to the commander for final approval and signature. The commander may keep the Final Report and only return the signed copy of the cover letter. The signed cover letter allows the inspection team to reproduce and distribute the Final Report.

Section 7.4

Completion Phase Step 15. Handoff

1. **Definition of Handoff.** Handoff is transferring of a verified finding to another command or organization for resolution that the Joint-level command cannot resolve. Handoff may occur through Command Channels by requesting assistance from the next higher Joint-level command or Joint staff for operational issues (for example, component support to a JTF) or through Joint IG Technical Channels such as forwarding the finding to the Joint Staff IG for information purposes (for example, if another COCOM IG had encountered the issue and may need advice or ideas on how to resolve the matter). The Joint IG will recommend handoffs to the commander during the inspection-results briefing since the Joint IG team will name the Joint staff directorate, outside agency, or Service as the proponent.

2. **Handoff Procedures.** Handoff can occur through Command Channels or Joint Staff IG Technical Channels. The procedures for each method are as follows:

a. **Command Channels.** The Joint-level command should have procedures in place for requesting assistance from the Joint Staff. If the issue concerns personnel, then the COCOM J-1 can work the problem with his or her counterpart at the Joint Staff J-1. In this case, the Joint Staff J-1 would have to track the problem as a tasker and monitor it to completion.

b. **Joint IG Technical Channels.** When using Joint IG Technical Channels for a handoff, the Joint IG should request assistance through the Joint Staff (JS) IG. The JS IG will then query all appropriate IG channels for possible solutions to issues. Next, the JS IG will notify the initiating Joint IG of potential solutions so that both IGs may discuss and resolve the issue. Finally, the initiating Joint IG must keep the commander informed of the handoff's progress.

Section 7.5

Completion Phase

Step 16. Distribute the Report

1. **Release Authority.** Upon the commander's approval of the inspection report, Joint IGs may release the written inspection reports for official use as long as the report meets the following criteria:

- a. Report is redacted of unit or individual information
- b. Report is not used to compare commands and commanders
- c. Report contains the appropriate markings (see paragraph three below)

2. **Distribute the Final Report.** Printed copies of the Final Report should go to the commander, primary staff members, the proponents, Service components, and any other component within the command (or outside the command) that may benefit from the results. If appropriate, provide courtesy copies to the Joint Staff IG and DoD IG for their awareness or assistance. If printing costs limit your ability to distribute the Final Report in hard-copy form, then circulate the Final Report electronically but only as a PDF file. Never send out a document someone else can manipulate or change on a computer. Ask your Information Resource Manager for help if necessary.

3. **Releasing IG Records.** Since you will be releasing Joint IG records within and outside the Joint command, ensure each page of the Final Report has the appropriate footer at the bottom. The footer explains that the Final Report is for official use only. Some parts of the document are exempt from mandatory disclosure under the Freedom of Information Act (FOIA). Exemption 5 applies to the release of inspection results. The correct footer is as follows:

FOR OFFICIAL USE ONLY

The COCOM commander or designated release authority will release Joint IG records in accordance with DoD Directive 5400.7, DoD Freedom of Information Act (FOIA) Program, and DoD 5400.11-R, DoD Privacy Program. See the Joint IG Concept and System Guide, Sections 4-3 and 4-4, for detailed procedures for records release for both official and non-official requests.

Section 7.6

Completion Phase

Step 17. Schedule a Follow-Up Inspection

1. **Scheduling a Follow-Up Inspection.** An inspection is meaningless if the inspection team does not follow up to determine if the necessary corrective actions have occurred. Following up is an important inspection principle that applies to all Joint IG inspections. The Joint IG team should schedule all follow-up activities to occur only after the command has had sufficient time to take corrective action.

2. **Techniques for Following Up.** A Joint IG can follow up an inspection using three different methods:

a. **Follow-Up Inspection.** The best method to determine if the results of the first inspection have been implemented is a complete re-inspection of the same topic. If an inspection topic is of particular importance to the Joint commander, a complete follow-up inspection may be the preferred method. However, a complete follow-up inspection is resource intensive and time consuming.

b. **Follow-Up Visit.** The Joint IG team members can visit the individuals or agencies responsible for taking the corrective action to determine their progress. The Joint IG team members must be careful not to assume a supervisory role over these proponents.

c. **Telephone.** This method is the same as a Follow-Up Visit except the Joint IG team members conduct a telephone interview/discussion.

Figure 7-2 shows the steps with the associated completed items.

Step 12	Step 13	Step 14	Step 15	Step 16	Step 17
Inspection Results Briefing	Monitor Completion	Completed Report	Command Channels	Distribution List	Follow up Schedule
		Commander's Cover Letter	IG Technical Channels	Redacted Report	

Figure 7-2
Completion Phase and Outputs

Chapter 8

Conducting a Compliance Inspection

Section 8.1 Conducting a Compliance Inspection

Section 8.2 Developing Inspection Checklists for Compliance Inspections

Section 8.1

Conducting a Compliance Inspection

1. **Purpose.** The purpose of this section is to describe a Compliance Inspection and how to conduct one.

2. **Overview.** A Compliance Inspection is focused on the health of a particular organization through compliance with established standards. The results contribute directly to the commander's readiness assessment of the organization. Table 8-1 provides a comparison of a Compliance Inspection with a Systemic Inspection.

Compliance Inspection	Systemic Inspection
Focused on the functional "health" of a specific command or component	Focused on the "health" of a particular function, process, or system using components as points of information
Results contribute directly to the commander's readiness assessment of the organization	Results positively impact the readiness of multiple components and not just one
Broad inspection areas	Narrow inspection areas
Compartmentalization of inspection areas	Systemic, integrated assessment of a focused inspection area
Short-term horizon	Long-term horizon
Cyclical in frequency and design	Linear in frequency and design
Distinguished by specialists who evaluate inspection results within a single commodity area	Integrates expertise from various specialties that contribute to research, design, and evaluation of the inspection results
Resolves local issues by assigning responsibility for corrective action at the lowest possible level	Resolves complex, high-payoff issues and assigns responsibility for corrective action to an individual or agency at the appropriate level
Component-based assessment that promotes accountability by the commanders for compliance	Systems-based assessment – free of component attribution or penalty – that promotes a deeper inquiry of the issues
Commander stresses performance in terms of efficiency and outputs (e.g., materiel readiness rates or number of Soldiers trained)	Commander stresses performance in terms of effectiveness and outcomes (qualitative perceptions of the impact of particular functions)
Views root cause issues from a hierarchical, organizational framework	Views root cause issues from a web-like team approach that spans functional and organizational lines
Assumes standards are correct as written	Does not assume the standards up and down the chain are correct

**Table 8-1
Compliance Inspection versus Systemic Inspection**

3. **Process.** Joint IGs may use the same 17 steps of the “Inspections Process” to conduct a Compliance Inspection. The Joint IG will review multiple programs within a component to determine overall readiness.

Compliance inspections are a combination of checklists and open-ended questions. Checklists are yes-no answers; however, the problem with checklists is they do not allow the Joint IG to dig deeper into the reasons for non-compliance. The Joint IG wants to know “why” there was non-compliance of the standard; therefore, open-ended questions should accompany the checklist (see Section 8-2). The result will be a greater understanding of the root causes associated with the component’s inability to comply with the established standard. A good open-ended question to begin a compliance inspection in a functional area is, “Would you briefly explain the component’s XXXX program?”

During the “Research Phase” of the inspections process, the Joint IG will focus on understanding the standard, who the proponent is, and why the standard exists. This research will assist the Joint IG in developing open-ended questions, checklist items, and educating the individuals responsible for compliance to the standard. Note: The Joint IG should assume the standards are correct as written.

Recommendations for resolving issues and taking corrective action are assigned at the lowest possible level. Thus, corrective action may be taken at the component or higher level, depending on where the root cause for non-compliance exists.

4. **Methodology.** Table 8-2 shows each of the 17 steps of the Compliance Inspection, and how they may or may not differ from the 17 Systemic Inspection steps shown in Chapter 4.

Inspection Step	Compliance Inspection	Systemic Inspection
1. Research	Focus on reviewing and understanding the standards to be inspected within a component (can be a broad range of topics)	Focus on how the system is suppose to work across many components (very narrow in scope)
2. Develop Concept	Develop multiple objectives based on number of standards inspected	Deep-dive into a single subject to find a roadblock in the system
3. Commander's Approval	No difference	No difference
4. Plan in Detail	May not conduct sensing sessions as an information-gathering technique	Requires sensing sessions as an information-gathering technique
5. Train Up	May not require a Subject Matter Expert (TAIG) Develop Compliance Questionnaire(s)	May require Subject Matter Expert (TAIG) Develop both Interview and Sensing Session questions
6. Pre-Inspection Visits	No Difference	No Difference
7. Visit Components	No Difference	No Difference
8. In-Process Review	No Difference	No Difference
9. Update Commander	No Difference	No Difference
10. Analyze Results and Cross-walk	No Difference	No Difference
11. Out-Brief the Proponent	No Difference	No Difference
12. Out-Brief the Commander	No Difference	No Difference
13. Issue Taskers	No Difference	No Difference
14. Finalize Report	No Difference	No Difference
15. Handoff	No Difference	No Difference
16. Distribute the Final Report	No Difference	No Difference
17. Schedule Follow-up Inspection	No Difference	No Difference

**Table 8-2
Differences in the 17 Steps of a Compliance and Systemic Inspection**

Section 8.2

Developing Inspection Checklists for Compliance Inspections

1. **Purpose.** This section discusses techniques for developing Inspection Checklists for Compliance Inspections.

2. **The Pitfalls of Inspection Checklists.** In the past, Compliance Inspections occurred with designated (and often untrained) inspectors who arrived at an inspected command, linked up with the various functional-area representatives, and then assessed the command's functional areas using a series of checklists. These checklists asked basic, close-ended questions (based upon the established standards) that the inspectors could simply check off as „yes“ or „no.“ The inspectors did not need to be experts in the subject matter to conduct these very basic, and extremely simplistic, inspections.

The problem with these checklists was they did not allow the inspectors to dig deeper into the reason for any non-compliance identified through the checklist. Instead, the inspectors noted that the command had failed to comply with one or more aspects of the standard governing the functional area and left it at that. In effect, the checklist did not facilitate a greater examination of the root causes behind the non-compliance. Neither the inspectors nor the inspected commanders could recommend or implement effective solutions for the non-compliant areas because they couldn't identify and understand the root causes behind the shortfalls.

3. **Getting at the Root Cause.** The only way to remedy the problem of identifying root causes while using checklists is to create checklists that combine close-ended questions (answered with a simple yes or no) with open-ended questions (answered by an in-depth explanation). Open-ended questions will allow the inspector to interact with the functional-area representative and explore in greater detail any reasons for non-compliance (see Section 3.4 on the Root Cause Analysis Model). The result will be a greater understanding of the root causes associated with the command's inability to comply with the established standard. However, for inspectors to understand the open-ended questions they are asking, they must have some measure of expertise in the inspected functional area.

4. **Sample Checklist.** The checklist below combines closed-ended questions with open-ended questions. The inspector must have the functional-area representative on hand for this inspection and not someone who is simply standing in for that person. The inspection of the functional area is, for the most part, an interview with the functional area representative intermingled with some physical, hands-on checking.

The inspector can begin the functional-area inspection by asking an open-ended question (Question 1 in this case) that will result in a discussion of the command's Radio Frequency Identification (RFID) program. By asking the command representative to explain the program, the inspector will be able to determine if the representative understands the regulation and the command's overall program. If the individual does not respond effectively, the inspector can ask the second part of the question (a follow-up question), which is a more direct query about the individual's knowledge of the

program and the associated standards. Once the inspector captures the essential information from these initial questions, the inspector can then ask Question 2, which is a close-ended question and requires the representative to show the inspector on-hand equipment.

The inspection will continue in this manner until the inspector gathers all of the required information about the functional area. The inspector will normally not offer an on-the-spot assessment of the functional area but will analyze the information later in conjunction with the established standard to determine if the command is in compliance with this particular functional area. The inspector will also be able to examine the information more closely for any root causes associated with the areas of non-compliance. The Root Cause Analysis Model in Section 3.4 will prove helpful in this determination.

The sample checklist is as follows:

Joint Task Force Yankee Inspection Checklist

(Applies to Initial Joint Command Inspections, Subsequent Joint Command Inspections and other Joint inspections as required)

Proponent: Under Secretary of Defense **Functional Area:** RFID Program **Checklist Date:** 12 August _____

Inspecting Office: _____ **Inspector/Phone:** _____

Unit Inspected: _____ **Date Inspected:** _____

Unit Functional Area Representative: _____

Reference(s): Under Secretary of Defense Policy Memorandum for RFID, dated 30 July 2004.

1. Would you briefly explain the unit's RFID Program?

Do you understand the Under Secretary of Defense Policy Memorandum governing the RFID program?

2. Does the unit have the proper hardware and software (V 2.0) to utilize RFID?

If not, why?

3. Does the unit properly code RFID tags in accordance with Business Rules for Passive RFID?

If not, why?

4. Does the unit properly palletize equipment to be shipped in accordance with Business Rules for Passive RFID?

If not, why?

5. Does the unit utilize the Electronic Data Interchange (EDI) information to generate transactions of records in DoD logistics systems?

If not, why?

6. Does the unit have a copy of the Under Secretary of Defense Policy Memorandum for RFID, dated 30 July 2004?

Chapter 9

Special Topics/Interests

- Section 9.1 Joint IG Intelligence Oversight Program
- Section 9.2 Confidentiality and Use of Records in Joint IG Intelligence Oversight
- Section 9.3 Personnel Accountability in Conjunction with Natural or Manmade Disasters
- Section 9.4 Managers Internal Control Program
- Section 9.5 Federal Voting Assistance Program

Section 9.1

Joint IG Intelligence Oversight Program

1. **Purpose.** This section provides background information about the Intelligence Oversight (IO) inspection process and the current rules and regulations that govern the system.
2. **The Joint IG Intelligence Oversight Guide.** Every Joint IG has a responsibility to inspect Intelligence Oversight programs. This includes the programs and proper reporting of Intelligence Oversight (IO) for their assigned Intelligence Community (IC); inspecting ICs as part of their command's IG Inspections Program; and establishing procedures for reporting of any questionable activities in accordance with Procedure 15, DoD 5240.1-R, to the Assistant Secretary of Defense for Intelligence Oversight (ATSD (IO)).
3. **History and Background.** The Intelligence Oversight Process is two-fold. One aspect ensures that select agencies within the Intelligence Community collect, retain, and disseminate information concerning U.S. persons only in accordance with certain procedures and regulations. The second aspect is to verify that intelligence personnel conduct intelligence operations in accordance with law, policy, and regulation and under appropriate authority. Section 2.3 of Executive Order (E.O.) 12333 provides the regulatory intelligence oversight guidance for the whole intelligence community. The intent of intelligence oversight is to ensure the privacy of U.S. citizens and other entities defined as U.S. persons and to ensure that the intelligence community operates within its charter of foreign intelligence and counterintelligence.

- a. The U.S. Constitution lays the basic groundwork in the Intelligence Oversight Process: the First Amendment allows U.S. citizens the freedom to express themselves without fear of Government reprisal while the Fourth Amendment protects U.S. citizens from unlawful searches and seizures. However, the need for additional intelligence oversight became evident in a 1974 New York Times article detailing operations the Central Intelligence Agency (CIA) had been conducting for several years. Thus, in 1975 the United States Senate Select Committee to Study Governmental Operations with Respect to Intelligence Activities, chaired by Senator Frank Church (D-ID), was formed.

- b. The Church Committee, as it is commonly known, investigated the intelligence-gathering efforts of both the CIA and the Federal Bureau of Investigation (FBI). This investigation revealed that Army intelligence components participated in the surveillance of U.S. citizens and organizations. Testimony before the committee revealed that "the Army's nationwide surveillance program created files on some 100,000 Americans and an equally large number of domestic organizations, encompassing virtually every group seeking peaceful change in the United States, including the John Birch Society, Young Americans for Freedom, The National Organization of Women, the NAACP, the Urban League, the Anti-Defamation League of B'nai B'rith, and Business Executives to End the War in Vietnam."¹ The information and testimony presented led the Committee to conclude that Congress needed to establish oversight standards and regulations. As a result of pressure from Congress and other groups, President Gerald Ford issued Executive Order 11905. In 1981 Executive Order 12333 replaced

¹ Intelligence Activities and the Rights of Americans, Book II, Final Report of the Select Committee to Study Governmental Operations with Respect to Intelligence Activities, United States Senate, April 26, 1976.

this order under authorization from President Ronald Reagan.

c. The Church Committee also spawned the creation of the Foreign Intelligence Surveillance Act (FISA) of 1978. The FISA outlines procedures for the physical and electronic surveillance and collection of “foreign intelligence information” between “foreign powers” and “agents of foreign powers,” which may include U.S. citizens and / or permanent residents.

d. The attacks of 11 September 2001 sparked a dramatic change in the intelligence community with the passing of the Patriot Act in 2001. By expanding the definition of terrorism to include “domestic terrorism,” the Act increased the ability of law-enforcement agencies to search telephone, e-mail communications, medical, financial, and other records; this Act also eased restrictions on foreign intelligence gathering within the U.S.

4. Policy Guidance for Intelligence Oversight. The following documents outline the established polices for IO in the Department of Defense.

a. Executive Order 12333, “United States Intelligence Activities”: The purpose of E.O. 12333 is to authorize robust collection while respecting the rights set forth by the Constitution. In addition, Section 2.3 mandates that the Attorney General must approve the intelligence collection procedures promulgated by agency heads, to include the Secretary of Defense.

b. Executive Order 13462, “President’s Intelligence Advisory Board and Intelligence Oversight Board”: Executive Order 13462 establishes the President’s Intelligence Advisory Board and the Intelligence Oversight Board, which advises the President on matters related to the Intelligence Community.

c. DoD Directive 5240.01, DoD Intelligence Activities, is the primary authority used by the Defense Intelligence Components and those performing an intelligence or counterintelligence function to collect, process, retain, or disseminate information concerning U.S. persons.

d. DoD Directive 5106.04, Combatant Command Inspectors General, requires Combatant Command IGs to inspect and report on command intelligence oversight programs pursuant to DoDD 5240.1.

e. DoD Instruction 5106.05, Combatant Command Inspectors General – Implementing Procedures, implements policy, assigns responsibilities, and provides procedures under DoDD 5106.04 to guide the Inspector General activities for Combatant Command IGs.

f. DoD 5240.1-R, Procedures Governing the Activities of DoD Intelligence Components that Affect US Persons, enables DoD intelligence components to carry out effectively their authorized functions while ensuring their activities that affect U.S. persons are carried out in a manner that protects the constitutional rights and privacy of such persons.

g. Chairman of the Joint Chiefs of Staff Instruction 5901.01, Joint Staff Inspector General Responsibilities, Procedures, and Oversight Functions, provides coordination and reporting procedures for the Joint Staff Inspector General in working with CJCS-controlled DoD activities, the Combatant Commands, DoD IG, and Military Department IGs.

h. Chairman of the Intelligence Oversight Board and Director of National Intelligence Memorandum on Intelligence Oversight Reporting Criteria, 17 July 2008, requires that significant or highly sensitive matters be reported immediately. These matters include intelligence activities that could impugn the reputation or integrity of the DoD intelligence community or otherwise call into question the propriety of these activities, whether or not the activities are unlawful or contrary to executive order, presidential directive, or applicable DoD policies.

5. **Applicability.** The Intelligence Oversight Process applies to DoD activities, agencies, and components; and Joint organizations.

6. **Responsibilities.** All personnel conducting, supervising, or providing staff oversight of intelligence activities, and who are involved in intelligence activities, are charged with ensuring that those activities are conducted properly.

a. Individuals assigned to or supporting Combatant Commands, JTFs, or other Joint Intelligence commands and/or performing intelligence activities will:

(1) Conduct intelligence activities only pursuant to, and in accordance with, Executive Order 12333, DoD 5240.1-R, and the authorized mission of their organization.

(2) Report Questionable Intelligence Activities (QIA) of E.O. 12333 or DoD 5240.1-R to their Commander, the Inspector General and/or General Counsel/Staff Judge Advocate immediately. Reporting should not be delayed and must be made to ATSD (IO) and the Joint Staff IG within five work days of discovery; therefore, Combatant Command directives and Joint organizational / JTF instructions may require more stringent reporting timelines.

b. Service Component Inspectors General will:

(1) Inspect Service intelligence oversight programs to ensure they are in compliance with Service requirements.

(2) Report any allegation of questionable intelligence activities to their Service Inspector General and Joint/Combatant Command or the appropriate defense agency Inspector General immediately upon receipt of an allegation in accordance with their Service Component regulatory guidance (e.g., within two (2) to five (5) days depending on the Military Service).

(3) Ensure that questionable activity is investigated under an appropriate authority to the extent necessary to determine the facts and assess whether the activity is legal and consistent with applicable policies.

(4) Obtain assistance from other DoD entities when necessary to complete the investigation in a timely manner.

c. Joint Inspectors General will:

(1) Monitor, inspect, and report on their command's intelligence oversight program. Seek the assistance of defense agency IGs in accordance with standing agreements.

(2) Conduct inspections and report on Joint intelligence oversight programs of those intelligent components or units assigned, attached, or under their administrative control at least once every 12 to 24 months.

(3) As part of an inspection, ensure procedures exist within the Combatant Command's headquarters and subordinate Joint intelligence organizations for the reporting of questionable activities and that employees of such organizations are aware of their responsibilities as specified in Procedures 14 and 15 of DoD 5240.1-R.

(4) Ensure the Headquarters' and subordinate Joint intelligence organizations report questionable intelligence activities (QIAs) to the Combatant Command IG and then forward these reports to ATSD (IO), the Joint Staff Deputy Inspector General (DIG), and appropriate defense agency (if applicable).

Note: All Combatant Command Joint Intelligence Operations Center/J-2 Directorate resources have been part of the Defense Intelligence Agency (DIA) Military Intelligence Program (MIP) since October 2008. These civilian intelligence personnel are DIA employees who operationally report to the Combatant Command's J-2. Administratively, DIA supports and funds them. DIA is in the process of finalizing all MIP-related programs, to include reporting and investigation procedures with each Combatant Command. QIA/Procedure 15 reports of investigation made by the Combatant Command IG should include DIA IG on all reports made to ATSD (IO) and the Joint Staff IG.

(5) Notify appropriate Military Service IGs of initiation and completion of Procedure 15/QIA-related investigative actions in accordance with Military Service requirements through the Combatant Command IG and the Joint Staff Deputy IG.

(6) Submit quarterly Intelligence Oversight reports covering the Headquarters' and JTF/subordinate Joint intelligence organizations to Joint Staff DIG no later than five work days after the beginning of each quarter (October, January, April, and July). See Appendix F for an example format of a typical Combatant Command quarterly IO report. Combatant Command IGs will also report questionable intelligence activities (as defined in reference I of Appendix B, paragraph 3) to ATSD (IO) and the Joint Staff DIG and appropriate agency IG (e.g., DIA). Combatant Command Service Components should send quarterly reports through Service channels in accordance with their Service regulations.

(7) Ensure questionable intelligence activities are investigated under an appropriate authority to the extent necessary to determine the facts and assess the activity as follows:

- Coordinate investigative activities with appropriate defense agency IGs. Investigate each report of questionable activity to the extent necessary to determine the facts and assess whether the activity is legal and consistent with applicable policies (see Appendix F for sample QIA and Quarterly report format and instructions).

- Conduct investigations expeditiously. Obtain assistance from other DoD components when necessary to complete an investigation in a timely manner.

- Retain overall responsibility for investigating questionable intelligence activities concerning the Combatant Command's headquarters and subordinate Joint organizations.

While the Combatant Command IG need not necessarily conduct the investigation, he or she should review the results of all investigations prior to submission to the Joint Staff.

- Combatant Command Service components will investigate and report questionable activities in accordance with Service regulations.

- Joint IGs must report allegations involving COCOM J-2 civilian personnel to the Defense Intelligence Agency (DIA) IG, and any investigations must occur in accordance with COCOM/DIA standing MOUs. COCOM and DIA IGs will coordinate investigations of COCOM J-2 civilian personnel; all other reporting requirements apply in accordance with existing CJCSI, DoD, and Federal guidance. The investigating IG will provide a copy of an issued report involving COCOM J-2 civilian personnel to the appropriate COCOM or DIA IG.

d. Joint Staff Deputy IG (DIG) will:

(1) Provide all reports of questionable intelligence activities to the Assistant to the Secretary of Defense (Intelligence Oversight) (ATSD (IO)) in accordance with DoD 5240.1-R, Procedure 15 and coordinate the forwarding of Combatant Command and JTF reports of investigation to Military Service IGs and DIA as applicable.

(2) Submit the consolidated quarterly IO report of the Combatant Commands to the ATSD (IO) no later than 10 work days after the beginning of each quarter (October, January, April, and July).

(3) Assist in resolving issues between the Inspectors General of the Military Departments, ATSD (IO), DIA, and Combatant Command IGs as required.

7. Reporting Requirements. Any civilian or military DoD employee within the DoD intelligence component has a basic responsibility to report any Questionable Intelligence Activity to an Office of the Inspector General and / or Office of the General Counsel. Table 1-1 is a Joint IG Intelligence Oversight Reporting Matrix.

a. "Questionable Intelligence Activity (QIA)," as defined by DoD 5240.1-R., is any intelligence or intelligence-related activity that may be unlawful or contrary to the references or other executive order, presidential directive, or applicable DoD policy governing those activities.

b. In accordance with DoD Directive-Type Memorandum (DTM) 08-052, issued by the Intelligence Oversight Board (IOB) and Director of National Intelligence (DNI), significant or highly sensitive matters must also be reported immediately. These matters include intelligence activities that could impugn the reputation or integrity of the DoD intelligence community or otherwise call into question the propriety of these activities, whether or not the activities are unlawful or contrary to executive order, presidential directive, or applicable DoD policies.

Examples include:

(1) Matters that are or may be the subject of Congressional inquiries or investigations.

(2) Matters resulting in a media event that has the potential of becoming (or actually is) a QIA (depends upon the judgment of the Joint IG).

(3) Matters that impact foreign relations or foreign partners.

(4) Unauthorized disclosures of protected information.

8. Training Requirements.

a. Intelligence components will establish training programs to ensure employee awareness as outlined in DoD 5240.1-R, Procedure 14.

b. Combatant Command IGs will ensure that procedures exist within the Combatant Command headquarters and subordinate Joint intelligence organizations for the reporting of questionable activities and that employees are aware of their responsibilities as specified by DoD 5240.1-R.

Joint IG Intelligence Oversight Reporting Matrix

	Quarterly IO Report	QIA (Procedure 15 Notification Rpts)	QIA Investigations
COCOM	Joint Staff	TO: ATSD (IO), The Joint Staff*, and DIA (if involving a DIA employee). INFO: COCOM or Service IG (as appropriate) if initiation of an investigation.	TO: ATSD (IO), The Joint Staff*, and DIA (if involving a DIA employee). INFO: COCOM or Service IG (as appropriate) with results of investigation.
JTF (JIOCs)	COCOM IG	COCOM IG	COCOM IG
Service Intelligence Components	TO: Service IO authority or COCOM IG if specified by COCOM regulations. INFO: COCOM or Service as appropriate.	TO: Service IO authority or COCOM IG if specified by COCOM regulations. INFO: COCOM or Service IG (as appropriate) if investigation is initiated.	TO: Service IO authority or COCOM IG if specified by COCOM regulations. INFO: COCOM or Service IG (as appropriate) with final results of investigation.

* The Joint Staff will also inform DIA and the applicable Service

**Table 1-1
Reporting Matrix**

Section 9.2

Confidentiality and Use of Records in Joint IG Intelligence Oversight

1. **Purpose.** The purpose of this section is to address how the key tenet of Joint IG confidentiality and the rules regarding the use of Joint IG records impact the execution of the intelligence oversight function.

2. **Confidentiality.** The Joint IG has a duty to protect an individual's confidentiality to the maximum extent possible, particularly when the individual specifically requests confidentiality.

a. Intelligence Oversight reporting requirements do not affect the principle of Joint IG confidentiality. An IG may provide the same level of confidentiality protection to someone reporting a Questionable Intelligence Activity (QIA) as he or she would in any other matter subject to the need to interview the person making the allegation or report in any subsequent inquiry. DoD 5240.1-R, requires that persons making a report of QIA be protected from reprisal or adverse action. If that protection is accomplished through confidentiality or some other means, any option is acceptable.

3. **Required Release.** QIA reports forwarded to ATSD (IO) and the Joint Staff from an Intelligence Component do not require, and normally do not include, the identity of the reporting individual or complainant.

4. **Intelligence personnel reporting requirements.** Individuals who become aware of activities they believe to be in violation of Intelligence Oversight regulations must report them to responsible authorities: the chain of command, Inspector General, General Counsel, Staff Judge Advocate, or other Legal authority; the DoD General Counsel; or the Assistant to the Secretary of Defense (Intelligence Oversight) (ATSD (IO)). If an intelligence person suspects that an activity his or her supervisor or higher authority may be asking him or her to conduct is improper, that person is obligated to ask for clarification before conducting the activity. If this request does not adequately satisfy the person's concerns, then he or she must seek out the intelligence oversight officer, the commander, the component's legal advisor, or the Joint Inspector General for clarification. No reprisal or adverse action may be taken against personnel for reporting possible violations of Intelligence Oversight regulations. Conversely, adverse action may be taken against personnel who were aware of violations but failed to report them.

5. **Joint IG Reporting Requirements.** Upon notification of or encountering questionable intelligence activity, Joint IGs will immediately report the issue through their Joint IG command IG channels (their respective COCOM IG office if applicable), which will notify ATSD (IO) through the Joint Staff Deputy IG. All Joint IGs must remember not to overlook proper security procedures. Notification to ATSD (IO) and the Joint Staff must be made within five work days of awareness.

6. **Records Release.** Reports of QIA under Procedure 15 are not considered IG records and are afforded no special protections other than those information security classifications required

by the content of the information in the report. This difference exists because the IG's role in the IO reporting system is a function shared with the legal community and the command reporting channels. They are reports within the IO community in which the IG is one of several reporting channels. In that an allegation made to an IG includes allegations of QIA along with other issues, the IG will process the portion reportable under Procedure 15 within IO channels. The Joint IG will not address other matters not related to the QIA in those channels. The records or reports of subsequent inquiries may be subject to the protections associated with the authorities under which they are conducted. For example, should a commander elect to investigate the allegation through an IG investigation/inquiry, the report of investigation / report of investigative inquiry (ROI/ROII) would be subject to protections and release as an IG record. The report resulting from a command investigation conducted under the authorities of Service or agency regulations would be considered a command product subject to release by the Directing Authority. At times, ATSD (IO) may require access to those products in order to assure the Intelligence Oversight Board (IOB) of how the issue was resolved.

a. Joint IG records, unless classified due to content, are for official use only (FOUO), and Joint IGs should manage, retain, and release them in accordance with established policy and procedures and classification requirements. Joint IG records are the property of the Department of Defense (DoD), and Joint IGs must maintain them in accordance with DoD policy and guidance pertaining to records use, maintenance, and release. Joint IG records management, protection, and release are discussed thoroughly in Chapter 4 of The Joint IG Concept and System Guide. Intelligence Oversight reporting and records information related to questionable intelligence activity must be provided to ATSD (IO) in accordance with DoD regulations.

b. The decisions on the disposition and dissemination of all IO-related reports ultimately belong to ATSD (IO) as Office of Primary Responsibility for IO in the DoD reporting chain. ATSD (IO) also has the authority to provide that information to whomever he/she deems appropriate for IO purposes. COCOM Commanders, their subordinate Joint commanders, or the Joint Staff do not have the authority to prevent reporting of QIAs to ATSD (IO). Executive Order, policy, and implementing DoD directives and regulations require these reports. ATSD (IO) does not provide general distribution of Procedure 15 reports to the Intelligence Components but reports them to the Intelligence Oversight Board (IOB) and the Office of the Director of National Intelligence (ODNI), as appropriate, and monitors resolution of issues raised with the responsible command.

Section 9.3

Personnel Accountability in Conjunction with Natural or Manmade Disasters

1. **Purpose.** This section describes the policy and responsibilities for accounting and reporting of specified DoD-affiliated personnel, within the continental United States (CONUS) and outside the continental United States (OCONUS), following a natural or manmade disaster.

2. **Policy.** Personnel accountability is a shared responsibility between the commander and/or supervisor and the individual. All DoD Components shall commence internal accountability activities immediately upon the occurrence of a disaster. Preplanned guidance and procedures shall be provided to all assigned or attached personnel so that they can establish accountability. All DoD Components shall report personnel accountability when directed.

a. All specified DoD-affiliated personnel who work or reside within the affected geographical area of a disaster as defined by the Chairman of the Joint Chiefs of Staff are required to positively and personally check in (for example; physically, telephonically, or electronically), at the first available opportunity, with the appropriate authority or emergency call-in number established by the DoD Component.

b. The Personnel Accountability Reporting System (PARS) will be the central repository used by all DoD Components when accomplishing personnel accountability upon the occurrence of a disaster.

EXCEPTION: Information required by DoD Instruction 3001.02 (Personnel Accountability in Conjunction With Natural or Manmade Disasters) that is determined to be classified in accordance with DoD 5200.1-R or to require protection due to operational security considerations in accordance with DoDD 5205.02 will be collected and maintained by a designated element of the Component on an appropriately classified system. The Component office maintaining the information will provide it as required by this Instruction via an appropriately classified system. Once provided, this information shall be maintained in classified channels.

3. **Responsibilities.** The Inspectors General of the DoD Components (Office of the Secretary of Defense (OSD), the Military Departments, Office of the Chairman of the Joint Chiefs of Staff (OCJC), Joint Staff, Combatant Commands (COCOM), DoD IG, Defense Agencies, and all other organizational entities within the Department of Defense) shall:

a. Conduct inspections biannually, beginning in calendar year 2011, of the personnel accountability programs in their respective Components to ensure compliance with this Instruction.

b. Upon completion of such inspections, forward a copy of the personnel accountability program inspection report to the Under Secretary of Defense for Personnel and Readiness (USD(P&R)) (ATTN: Military Community and Family Policy) and a courtesy copy to the DoD Inspector General (ATTN: Inspections and Evaluations). The report is due in February 2012 and in February of every even-numbered year thereafter.

Section 9.4

Managers Internal Control Program

1. **Purpose.** This section describes the Managers Internal Control Program (MICP) and the responsibilities of the Joint Inspector General.

2. **Scope.** Internal control is a major part of managing an organization. Internal Control is the plan, method, and procedure used to meet missions, goals, and objectives and, in doing so supports performance-based management. Internal control also serves as the first line of defense in safeguarding assets and preventing and detecting errors and fraud. In short, internal control, which is synonymous with management control, helps government program managers achieve desired results through effective stewardship of public resources.

a. Internal control should provide reasonable assurance that the objectives of the agency are being achieved in the following categories:

- Effectiveness and efficiency of operations including the use of the entity's resources
- Reliability of financial reporting, including reports on budget execution, financial statements, and other reports for internal and external use.
- Compliance with applicable laws and regulations.

b. A subset of these objectives is the safeguarding of assets. Internal control should be designed to provide reasonable assurance regarding prevention of or prompt detection of unauthorized acquisition, use, or disposition of an agency's assets

3. **Five Standards for Internal Control.** These standards define the minimum level of quality acceptable for internal control in government and provide the basis against which internal control is to be evaluated. These standards apply to all aspects of an agency's operations: programmatic, financial, and compliance. However, they are not intended to limit or interfere with duly granted authority related to developing legislation, rule-making, or other discretionary policy-making in an agency. These standards provide a general framework. In implementing these standards, management is responsible for developing the detailed policies, procedures, and practices to fit their agency's operations and to ensure that they are built into and an integral part of operations.

a. **Control Environment** - Management and employees should establish and maintain an environment throughout the organization that sets a positive and supportive attitude toward internal control and conscientious management

b. **Risk Assessment** - Internal control should provide for an assessment of the risks the agency faces from both external and internal sources.

c. **Control Activities** - Internal control activities help ensure that management's directives are carried out. The control activities should be effective and efficient in accomplishing the agency's control objectives.

d. **Information and Communications** - Information should be recorded and communicated to management and others within the entity who need it and in a form and within a time frame that enables them to carry out their internal control and other responsibilities.

e. **Monitoring** - Internal control monitoring should assess the quality of performance over time and ensure that the findings of audits and other reviews are promptly resolved.

4. **Joint IG Responsibilities.** See references listed in Appendix B, Paragraph 5.

Section 9.5

Federal Voting Assistance Program

1. **Purpose.** This section describes DoD Policy and responsibilities for the Federal Voting Assistance Program (FVAP)

2. **DoD Policy.** It is DoD Policy that:

a. The Heads of the DoD Components and the Uniformed Services shall encourage eligible voters in their organizations to register and vote in elections for Federal, State, and local office.

b. The FVAP shall ensure that eligible voters receive, under Appendix B, Paragraph 6, reference (e), information about registration and voting procedures and materials pertaining to scheduled elections, including dates, offices, constitutional amendments, and other ballot proposals.

c. Every eligible voter shall:

1. Be given, unless military necessity precludes it, an opportunity to register and vote in any election for which he or she is eligible.

2. Be able to vote in person or by absentee process when local conditions allow the voter to participate in the electoral process.

3. Receive voting assistance in a manner that safeguards the integrity of the electoral process and secrecy of the ballot.

4. All persons assisting in the voting process shall take all necessary steps to prevent fraud and to protect voters against any coercion, including the following:

4.1. No member of the Uniformed Services shall attempt to influence the vote of any other member, or to require any member to march to any polling place or place of voting as proscribed under 18 U.S.C. 608 and 609 (Appendix B, Paragraph 6, references (b thru d)). Nothing in this Directive shall be considered to prohibit free discussion about political issues or candidates for public office as proscribed in Appendix B, Paragraph 6, references (b thru d).

4.2. No person shall poll any member of the Armed Forces before or after he or she votes, as proscribed in Appendix B, Paragraph 6, references (b thru d). If any such member is polled, that event shall be reported through the chain of command to the Director, Federal Voting Assistance Program.

4.3. Nothing in this Directive shall preclude conducting official surveys authorized by Appendix B, Paragraph 6, reference (e) to report to the President and the Congress on the effectiveness of the assistance provided to eligible voters, including a separate statistical analysis of voter participation and a description of Federal-State cooperation.

3. **Responsibilities**

a. The Inspector General of the Department of Defense : In accordance with 10 U.S.C. 1566 (Appendix B, Paragraph 6), the Inspector General of the Department of Defense shall periodically conduct, at DoD installations, unannounced assessments of those installations' compliance with the provisions of Appendix B, Paragraph 6, reference (e).

b. The Inspectors General of the Military Departments: shall provide a report of their assessment to the Inspector General of the Department of Defense, by January 31 of each year. Refer to service specific instructions in Appendix B Paragraph 6.

c. Combatant Commanders: Combatant Commanders bear additional responsibility to ensure that deployed forces have access to federal voting assistance information, particularly in remote or difficult locations. Combatant Commanders shall highlight within the operational chain of command the importance they and the Department attach to participation by U.S. forces in the Federal, State, and local election processes.

Appendix A

GLOSSARY

PART I. ABBREVIATIONS AND ACRONYMS

A

A-1	Air Force Manpower / Personnel Directorate
A-2	Air Force Intelligence Directorate
A-3	Air Force Operations Directorate
A-4	Air Force Logistics Directorate
A-5	Air Force Plans Directorate
A-6	Air Force Command, Control, and Communications Directorate
AIG	Assistant Inspector General
AOR	area of responsibility
ATSD(IO)	Assistant Secretary of Defense for Intelligence Oversight

C

CDR	Commander
CI	counterintelligence
CIA	Central Intelligence Agency
CJCS	Chairman of the Joint Chiefs of Staff
CJTF	Commander, Joint Task Force
COCOM	Combatant Commanders
CONUS	continental United States

D

DEPSECDEF	Deputy Secretary of Defense
DIA	Defense Intelligence Agency
DIG	Deputy Inspector General
DNI	Director of National Intelligence
DoD	Department of Defense
DoDD	Department of Defense Directive
DoDI	Department of Defense Instruction
DOTMLPF	Doctrine-Organization-Training-Material Leadership/Education-Personnel-Facilities

DTM Directive-Type Memorandum

E

ECIE Executive Council on Integrity and Efficiency
ECRC Expeditionary Combat Readiness Center
E.O. Executive Order

F

FBI Federal Bureau of Investigation
FedEx Federal Express
FI foreign intelligence
FISA Foreign Intelligence Surveillance Act
FOIA Freedom of Information Act
FOUO for official use only
FRAGO fragmentary order
FVAP Federal Voting Assistance Program

G

G-1 Army or Marine Corps Manpower or Personnel Staff Officer
G-2 Army or Marine Corps intelligence Staff Officer
G-3 Army or Marine Corps operations Staff Officer
G-4 Army or Marine Corps Logistics Staff Officer
G-5 Army or Marine Corps Planning Staff Officer
G-6 Army or Marine Corps Command, Control, Communications, and Computer Systems Staff Officer
G-7 Army or Marine Corps Information Operations Staff Officer

I

IA individual augmentation
IC intelligence community
ICOM Inputs, Controls, Outputs, and Mechanisms
IG Inspector General
IIA incident assessment and awareness
IO Intelligence Oversight
IOB Intelligence Oversight Board

IOO Intelligence Oversight Officer
IPR in-process review
ISR

J

J-1 Manpower and personnel directorate of a joint staff; manpower & personnel staff section
J-2 Intelligence Directorate of a Joint Staff; Intelligence Staff section
J-3 Operations Directorate of a Joint Staff; Operations Staff section
J-35 Future Operations of a Joint Staff
J-4 Logistics Directorate of a Joint Staff; Logistics Staff section
J-5 Plans Directorate of a Joint staff;
J-6 Communications System Directorate of a Joint Staff;
J-7 Engineering staff; Operational Plans and Interoperability Directorate of a Joint Staff
J-8 Joint Staff; Force Structure, Resource, and Assessment Directorate of a Joint Staff
J-9 Civil-Military Operations Directorate of a Joint Staff;
JCIG Joint Command Inspector General
JMD Joint Manning Document
JMETL Joint Mission Essential Task List
JIOC Joint Intelligence Operations Center
Joint IG Joint Inspectors General
JS Joint Staff
JS DIG Joint Staff Deputy Inspector General
JSCP Joint Strategic Capabilities Plan
JSM Joint Staff Manual
JTD Joint Table of Distribution
JTF Joint Task Force
JTMD Joint Table of Mobilization Document
JTTP joint tactics, techniques, and procedures

M

Maj Major
MICP Managers Internal Control Program
MIP Military Intelligence Program

N

N-1 Navy component manpower or personnel staff officer

N-2	Navy component intelligence staff officer
N-3	Navy component operations staff officer
N-4	Navy component logistics staff officer
N-5	Navy component plans staff officer
N-6	Navy component communications staff officer
NAACP	National Association for the Advancement of Colored People
NCA	National Command Authorities
NCO	Non-Commissioned Officer

O

OCJC	Office of the Chairman of the Joint Chiefs of Staff
OCONUS	Outside the Continental United States
ODNI	Office of the Director of National Intelligence
OIG	Office of Inspector General
OPLAN	operation plan
OPNAV	Chief of Naval Operations
OSD	Office of the Secretary of Defense

P

PARS	Personnel Accountability Reporting System
PCIE	President's Council on Integrity and Efficiency

Q

QIA	questionable intelligence activities
-----	--------------------------------------

R

RFID	radio frequency identification
ROI	report of investigation
ROII	report of investigative inquiry
RSOI	reception, staging, onward movement, and integration

S

SECDEF	Secretary of Defense
SECNAV	Secretary of the Navy

SIGINT	Signal Intelligence
SJS	Secretary to the Joint Staff
SME	subject-matter experts
SOP	standard operating procedures

T

TAIG	Temporary Assistant Inspector General
------	---------------------------------------

U

UCP	Unified Command Plan
UJTL	Universal Joint Task List
USD(P&R)	Under Secretary of Defense for Personnel and Readiness

PART II. DEFINITIONS

assistance. The process of receiving, inquiring, recording, and responding to complaints or requests either brought directly to the Joint IG or referred to the Joint IG for action.

administrative purposes. Information is collected for "administrative purposes" when it is necessary for the administration of the component concerned but is not collected directly in performance of the intelligence activities assigned such component. Examples include information relating to the past performance of potential contractors; information to enable such components to discharge their public affairs and legislative duties, including the maintenance of correspondence files; the maintenance of employee personnel and training records; and training materials or documents produced at training facilities.

available publicly. Information that has been published or broadcast for general public consumption, is available on request to a member of the general public, could lawfully be seen or heard by any casual observer, or is made available at a meeting open to the general public. In this context, the "general public" also means general availability to persons in a military community even though the military community is not open to the civilian general public.

collection. Information is considered "collected" only when an employee of a Defense Intelligence Component or contractors working on behalf of Defense Intelligence Components receive it in the course of official duties and retain it with the intent for intelligence use. Data acquired by electronic means (e.g.; telemetry, signals traffic analysis, measurement and signatures intelligence) is "collected" only when it has been processed from digital form into a form intelligible to a human being. The use of the Internet to obtain publicly available information may constitute collection if that information is downloaded or copied for use.

communications security. Protective measures taken to deny unauthorized persons information derived from telecommunications of the United States Government related to national security and to ensure the authenticity of such telecommunications.

consent. The agreement by a person or organization to permit DoD intelligence components to take particular actions that affect the person or organization. Consent may be oral or written unless a specific form of consent is required by a particular procedure. Consent may be implied if adequate notice is provided that a particular action (such as entering a building) carries with it the presumption of consent to an accompanying action (such as search of briefcases). (Questions regarding what is adequate notice in particular circumstances should be referred to the legal office responsible for advising the DoD intelligence component concerned.)

counterintelligence. Information gathered and activities conducted to protect against espionage, other intelligence activities, sabotage, or assassinations conducted for or on behalf of foreign powers, organizations, or persons, or international terrorist activities, but not including personnel, physical, document, or communications security programs.

Directing Authority. Any DoD official who has the authority to direct the conduct of an IG investigation or inspection is a directing authority. Within the Joint communities, the

Directing Authorities are the Secretary of Defense (SECDEF); the Director Joint Staff / Joint Staff IG; Combatant Commanders; Joint Commanders; and Joint Command IGs. Joint Commanders who are authorized IGs on their staffs may direct IG investigations and inspections within their commands. The SECDEF, Director of the Joint Staff, Joint Staff IG and COCOM Commanders may direct IG investigations and inspections within subordinate commands as necessary.

dissemination. The term "dissemination" refers to the distribution of U.S. person information, without the consent of the U.S. person, outside of the DoD intelligence component that collected and retained the information. It does not apply to information collected for administrative purposes or disseminated pursuant to law or pursuant to a court order that otherwise imposes controls upon such dissemination.

eligible voter. Any of the following:

An "absent Uniformed Services voter," defined as an active duty member of the Uniformed Services or a member of the Merchant Marine who is absent from the place of residence where he or she is otherwise qualified to vote, and their accompanying dependents.

An "overseas voter," defined as:

An absent Uniformed Services voter who, by reason of active duty or service, is absent from the United States on the date of the election;

A person who resides outside the United States and is qualified to vote in the last place in which the person was domiciled before leaving the United States; or

A person who resides outside the United States and (but for such residence) would be qualified to vote in the last place in which the person was domiciled before leaving the United States.

employee. A person employed by, assigned to, or acting for an agency within the intelligence community, including contractors and persons otherwise acting at the direction of such agency.

foreign intelligence. Information relating to the capabilities, intentions, and activities of foreign powers, organizations, or persons, but not including counterintelligence except for information on international terrorist activities.

Inspector General records. Any written or recorded Joint IG work product created during the course of an inquiry, investigation or inspection to include; documents, case notes, files, electronic files, digital/tape recordings, video recordings, photos and working papers.

incident assessment and awareness. The use of DoD intelligence, surveillance, and reconnaissance capabilities for domestic non-intelligence activities approved by the Secretary of Defense such as search and rescue, damage assessment, and situational awareness.

inspection. A process that evaluates, reviews, studies, and/or analyzes the programs and activities of a Department/Agency for the purposes of providing information to managers for

decision making; making recommendations for improvements to programs, policies, or procedures; and identifying where administrative action may be necessary.

intelligence activity. All activities that Defense Intelligence Components are authorized to undertake pursuant to Executive Order, law, policy and governing regulations. The term also includes the intelligence activities of Defense non-Intelligence organizations whose sole mission is not intelligence.

Intelligence Oversight Officer. An individual assigned to establish intelligence oversight procedures and training programs; evaluate component or division personnel IO knowledge; and resolve collectability determinations in consultation with his or her servicing legal advisor.

intelligence-related activity. Those activities outside the consolidated defense intelligence program that respond to operational commanders' taskings for time-sensitive information on foreign entities; respond to national intelligence community taskings of systems whose primary mission is support to operating forces; train personnel for intelligence duties; provide an intelligence reserve; or are devoted to research and development of intelligence or related capabilities. (Specifically excluded are programs that are so closely integrated with a weapon system that their primary function is to provide immediate-use targeting data.)

internal control. The organization, policies, procedures, instructions, adopted by management to reasonably ensure that mission or operational objectives are met, that programs achieve intended results and to help managers safeguard the integrity of their programs.

international terrorist activities. Activities undertaken by or in support of terrorists or terrorist organizations that occur totally outside the United States, or that transcend national boundaries in terms of the means by which they are accomplished, the persons they appear intended to coerce or intimidate, or the locale in which the perpetrators operate or seek asylum.

investigation.

An investigation is a fact-finding examination by a Joint IG into allegations, issues, or adverse conditions to provide the Directing Authority a sound basis for decisions and actions. IG investigations normally address allegations of wrongdoing by an individual and are authorized by written directives. IG investigations involve the systematic collection and examination of evidence that consists of testimony; documents; and, in some cases, physical evidence. Joint IGs report the results using the Report of Investigation format addressed in Chapter 9 of this guide.

IG investigations are characterized by:

An investigation directive issued by the commander providing written authority to examine the issues or allegations in question.

A process providing a road map of how to proceed. These steps standardize procedures, protect individual rights, ensure proper command notifications, and protect the confidentiality of individuals and the IG system.

A format for documenting the results in the form of a Report of Investigation.

investigative inquiry.

An investigative inquiry is an informal fact-finding process to gather information needed to address allegations of impropriety against an individual that can accomplish the same objectives as an IG investigation. Joint IGs normally use this investigative process when the involvement of the directing authority is not foreseen. However, this fact does not preclude directing authorities from directing an investigative inquiry. Joint Command IGs typically direct the investigative inquiry and provide recommendations to their commanders or to subordinate commanders as appropriate.

IGs conduct investigative inquiries to gather information needed to respond to a request for assistance or resolve allegations or issues concerning alleged misconduct on the part of an individual(s). An IG investigative inquiry may be necessary when investigative techniques are appropriate but circumstances do not warrant an IG investigation. An investigative inquiry has no requirement for a written directive from the commander. You may employ investigation techniques (for example, sworn and recorded testimony) when conducting investigative inquiries. These techniques enhance the thoroughness of the fact-finding process. Joint IGs report the results using the Report of Investigative Inquiry (ROI) format addressed in Chapter 9 of this guide.

Investigation versus Investigative Inquiry

- Investigations are more formal and require a directive from the commander
- Investigative Inquiries are informal and do not require a directive
- Both are thorough
- Both are fair and impartial
- Both support a decision
- Both are properly documented
- Investigation recommendations – a Joint IG makes recommendations to the Directing Authority if requested
- Investigative Inquiry recommendations – a Joint IG may make recommendations to subordinate commanders and / or the Directing Authority

Joint IGs frequently conduct investigative inquiries in response to allegations of impropriety. They conduct investigations less frequently. Both forms of fact-finding have the common characteristics of fairness, impartiality, confidentiality, and thoroughness.

Joint Inspector General. Officers, non-commissioned officers and civilians from the Army, Navy, Air Force, Marines and Coast Guard who are assigned to duty as an IG in a Joint command, primarily Combatant Commands and Joint Task Forces and other unique Joint organizations by exception.

Joint Intelligence Operations Center. An interdependent, operational intelligence organization at the Department of Defense, combatant command, or joint task force (if established) level that is integrated with national intelligence centers and capable of accessing all sources of intelligence impacting military operational planning, execution, and assessment.

Manager's Internal Control Program. The formal effort of an organization to ensure that IC systems are working effectively through assignment of responsibilities at the policy level, issuance and implementation of guidance, conduct of internal control evaluations, and reporting to senior management.

physical security. The physical measures taken to prevent unauthorized access to, and prevent the damage or loss of, equipment, facilities, materiel and documents; and measures undertaken to protect DoD personnel from physical threats to their safety.

physical security investigation. All inquiries, inspections, or surveys of the effectiveness of controls and procedures to provide physical security; and all inquiries and other actions undertaken to obtain information pertaining to physical threats to DoD personnel or property.

poll. Any request for information regarding the content of an individual's vote.

proponent. Person or agency that espouses or supports a cause.

questionable intelligence activity. Any action that constitutes, or is related to, an intelligence activity that may violate applicable laws, Executive Orders, Presidential Directives or applicable DoD policies and regulations governing such intelligence activity.

reasonable belief. A reasonable belief arises when the facts and circumstances are such that a reasonable person would hold that belief. Reasonable belief must rest on facts and circumstances that can be articulated; hunches or intuitions are not sufficient. Reasonable belief can be based on experience, training, and knowledge in foreign intelligence or counterintelligence work applied to facts and circumstances at hand so that a trained and experienced "reasonable person" might hold a reasonable belief sufficient to satisfy this criterion when someone is unfamiliar with foreign intelligence or counterintelligence.

retention. The term "retention", as applied to information collected on U.S. persons, refers to the maintenance of U.S. person information that can be retrieved by reference to the person's name or other identifying data.

special activities. Activities conducted in support of national foreign policy objectives abroad, which are planned and executed so that the role of the U.S. Government is not apparent or acknowledged publicly, and functions in support of such activities, but which are not intended to influence U.S. political processes, public opinion, policies, or media, and do not include diplomatic activities or the collection and production of intelligence or related support functions.

United States person (USPER).

The term "United States person" means:

- A United States citizen;
- An alien known by the DoD intelligence component concerned to be a permanent resident alien;
- An unincorporated association substantially composed of United

States citizens or permanent resident aliens;

- A corporation incorporated in the United States, except for a corporation directed and controlled by a foreign government or governments. A corporation or corporate subsidiary incorporated abroad, even if partially or wholly owned by a corporation incorporated in the United States, is not a United States person.

A person or organization outside the United States shall be presumed not to be a United States person unless specific information to the contrary is obtained. An alien in the United States shall be presumed not to be a United States person unless specific information to the contrary is obtained.

A permanent resident alien is a foreign national lawfully admitted into the United States for permanent residence.

Appendix B

References

1. **Purpose.** The references used in developing this guide are the key regulations and publications that apply to the Joint conduct of key functions in general and Joint Inspector General systems in particular.
2. **Critical References.** The following references represent those publications considered essential to developing a solid understanding of Joint doctrine, particularly as it relates to the conduct of Joint Inspector General functions.
 - a. 10 USC Chapter 5, "Joint Chiefs of Staff."
 - b. 10 USC Chapter 38, "Joint Officer Management."
 - c. 10 USC Sec 141, "Office of Secretary of Defense- Inspector General."
 - d. 10 USC Sec 151, "Joint Chiefs of Staff- Composition and Functions."
 - e. 10 USC Sec 153, "Chairman Functions."
 - f. 10 USC Sec 155, "Joint Staff."
 - g. 10 USC Sec 163, "Role of Chairman of Joint Chiefs of Staff."
 - h. 10 USC Sec 165, "Combatant Commands- Administration and Support."
 - i. 10 USC Sec 181, "Joint Requirements Oversight Council."
 - j. PCIE/ECIE, "Quality Standards for Inspections", January 2005.
 - k. DoD 5500.7-R, "Joint Ethics Regulation."
 - l. DoD Directive 5106.01, "Inspector General of the Department of Defense."
 - m. DoD Directive 5100.03, "Support of Headquarters of Combatant and Subordinate Joint Commands."
 - n. DoD Directive 5106.04, "Combatant Command Inspectors General."
 - o. DoD Instruction 1100.13, "Surveys of DoD Personnel."
 - p. DoD Instruction 7050.03, "Access to Records and Information by the Inspector General, Department of Defense."
 - q. DoD Instruction 7050.05, "Coordination of Remedies for Fraud and Corruption Related to Procurement Activities."

- r. DoD Instruction 5106.05, "Combatant Command Inspectors General - Implementing Procedures."
- s. CJCS Manual 3500.03, "Joint Training Manual for the Armed Forces of the United States."
- t. CJCS Manual 3500.04E, "Universal Joint Task Manual."
- u. CJCS Manual 3500.05, "Joint Task Force Headquarters Master Training Guide."
- v. CJCS Manual 5760.01, "Joint Staff – Combatant Command Records Management Manual: Volume I-- Procedures."
- w. CJCS Manual 5760.01, "Joint Staff – Combatant Command Records Management Manual: Volume II -- Disposition Schedule."
- x. CJCS Instruction 3500.01, "Joint Training Policy and Guidelines."
- y. CJCS Instruction 3500.02, "Universal Joint Task List (UJTL) Policy and Guidance for the Armed Forces of the United States."
- z. CJCS Instruction 5120.02B, "Joint Doctrine Development System."
- aa. CJCS Instruction 5705.01C, "Standardization of Military and Associated Terminology."
- bb. CJCS Instruction 5901.01B, "Joint Staff Inspector General Responsibilities, Procedures, and Oversight Functions."
- cc. CJCS Notice 3500.01, "2011-2014 Chairman's Joint Training Guidance."
- dd. Joint Publication 1-0, "Personnel Support to Joint Operations."
- ee. Joint Publication 3-0, "Joint Operations."
- ff. Joint Publication 4-0, "Joint Logistics."
- gg. Joint Publication 5-0, "Joint Operation Planning."
- hh. Joint Publication 6-0, "Joint Communications System."
- ii. Joint Staff Manual 5711.01D, "Joint Staff Correspondence Preparation."
- jj. OPNAV Instruction 5216.10K, "US Navy Guide Book for Joint Actions."

3. Key Intelligence Oversight Program Publications. The following is a listing of key references and publications used by DoD Component Agencies and the Service IGs to provide intelligence oversight program monitoring for military intelligence components. These publications represent both policy and doctrine for intelligence oversight.

- a. Executive Order 12333, "United States Intelligence Activities."

- b. Executive Order 13462, "President's Intelligence Advisory Board and Intelligence Oversight Board."
- c. DoD 5240.1-R, "Procedures Governing the Activities of DoD Intelligence Components that Affect United States Persons."
- d. DoD Directive 5106.1, "Inspector General of the Department of Defense."
- e. DoD Directive 5106.04, "Combatant Command Inspectors General."
- f. DoD Directive 5148.11, "Assistant to the Secretary of Defense for Intelligence Oversight (ATSD(IO))."
- g. DoD Directive 5240.1, "DoD Intelligence Activities."
- h. DoD Directive 5525.5, "DoD Cooperation with Civilian Law Enforcement Officials."
- i. DoD Instruction 5106.05, "Combatant Command Inspectors General Implementing Procedures."
- j. DoD Instruction 8910.01, "Information Collection and Reporting."
- k. Directive-Type Memorandum (DTM) 08-011, "Intelligence Oversight Policy Guidance."
- l. Directive-Type Memorandum (DTM) 08-052, "DoD Guidance for Reporting Questionable Intelligence Activities and Significant or Highly Sensitive Matters."
- m. CJCSI 5901.01, "Joint Staff Inspector General Responsibilities, Procedures, and Oversight Functions."

Service Policy and Doctrinal Publications: The following Service-specific policy and publications provide insight into the rules and doctrine that will assist Joint IGs in the conduct of their duties:

- a. **Army:**
 - (1) Army Regulation 381-10, "U.S. Army Intelligence Activities."
- b. **Navy:**
 - (1) SECNAV Instruction 3820.3, "Oversight of Intelligence Activities Within the Department of the Navy (DON)."
 - (2) SECNAV Instruction 5000.34, "Oversight and Management of Intelligence Activities, Intelligence-Related Activities, Special Access Programs, Covert Action Activities and Sensitive Activities within the Department of the Navy."
 - (3) SECNAV Instruction 5000.38, "Oversight of the Department of the Navy Military Intelligence Program."
- c. **U.S. Marine Corps:**

(1) Marine Corps Order 3800.2B, "Oversight of Intelligence Activities."

d. **U.S. Air Force:**

(1) Air Force Instruction 14-104, "Oversight of Intelligence Activities."

Other Guidelines or Standards:

a. Chairman of the Intelligence Oversight Board and Director of National Intelligence Memorandum on Intelligence Oversight Reporting Criteria, 17 July 2008

b. JP 2-0, "Joint Intelligence."

4. Department of Defense(DoD) Directives and Instructions that apply to Personnel Accountability in Conjunction With Natural or Manmade Disasters:

a. DoD Directive 1332.35, "Transition Assistance for Military Personnel."

b. DoD Directive 1400.31, "DoD Civilian Work Force Contingency and Emergency Planning and Execution."

c. DoD Directive 3025.14, "Protection and Evacuation of U.S. Citizens and Designated Aliens in Danger Areas Abroad (Short Title: Noncombatant Evacuation Operations)."

d. DoD Directive 5124.02, "Under Secretary of Defense for Personnel and Readiness (USD(P&R))."

e. DoD Directive 5205.02, "DoD Operations Security (OPSEC) Program."

f. DoD Instruction 1100.22, "Policy and Procedures for Determining Workforce Mix."

g. DoD Instruction 1300.18, "Department of Defense (DoD) Personnel Casualty Matters, Policies, and Procedures."

h. DoD Instruction 1304.25, "Fulfilling the Military Service Obligation (MSO)."

i. DoD Instruction 1400.32, "DoD Civilian Work Force Contingency and Emergency Planning Guidelines and Procedures."

j. DoD Instruction 3001.02, "Personnel Accountability in Conjunction With Natural or Manmade Disasters."

k. DoD Instruction 3020.41, "Contractor Personnel Authorized to Accompany the U.S. Armed Forces."

l. Directive-Type Memorandum (DTM) 08-005 (Building Increased Civilian Deployment Capacity)

m. DoD 5200.1-R, "Information Security Program."

- n. Joint Travel Regulations, Volume 2, "Department of Defense Civilian Personnel."
- o. CJCS Manual 3150.13C, "Joint Reporting Structure - Personnel Manual."

Service Automated Websites for Personnel Accountability Reporting Systems:

- a. **Army:** Army Disaster Personnel Accountability and Assessment System (ADPAAS): <https://adpaas.army.mil/>.
- b. **Navy:** Navy Family Accountability and Assessment System (NFASS): <https://navyfamily.navy.mil/>.
- c. **U.S. Marine Corps:**
 - (1) Marine On Line: Planned Location Information: <https://tfas.mol.usmc.mil/>.
 - (2) Manpower Information System Support Offices: MISSO 03 ADVISORY 22-20090130 (REPORTING PLANNED LOCATION INFORMATION).
- d. **U.S. Air Force:** Air Force Personnel Accountability and Assessment System (AFPAAS): <https://afpaas.af.mil/>.

5. Department of Defense (DoD) Directives and Instructions that apply to the Managers Internal Control Program:

- a. 31 USC Sec 3512, "Executive Agency Account and Other Financial Management Reports and Plans."
- b. Public Law 97-255, "Federal Managers Financial Integrity Act of 1982."
- c. Executive Order 12931, "Federal Procurement Reform."
- d. GAO/AIMD-00-21.3.1, "Standards for Internal Control in the Federal Government."
- e. DoD Instruction 5010.40, "Managers" Internal Control Program (MICP) Procedures."

Service Policy and Doctrinal Publications: The following Service-specific policy and doctrinal publications provide insight into the rules and doctrine that will assist Joint IGs in the conduct of their duties:

- a. **Army:**
 - (1) Army Regulation 11-2, "Managers" Internal Control Program."
- b. **Navy:**
 - (1) SECNAV Instruction 5200.35E, "Department of the Navy (DON) Managers" Internal Control (MIC) Program."
 - (2) OPNAV Instruction 5200.25C, "CNO Management Control Program."

- c. **U.S. Marine Corps:**
 - (1) Marine Corps Order 5200.24D, "Marine Corps Managers" Internal Control (MCMIC) Program."
- d. **U.S. Air Force:**
 - (1) Air Force Policy Directive (AFPD) 65-2, "Managers" Internal Control Program."

6. Department of Defense (DoD) Directives and Instructions and United States Codes that apply to the Federal Voters Assistance Program (FVAP):

- a. Title 10 United States Code, Section 1566, "Voting Assistance: Compliance Assessments; Assistance."
- b. Title 18 United States Code, Section 596, "Polling Armed Forces."
- c. Title 18 United States Code, Section 608, "Absent Uniformed Services Voters and Overseas Voters."
- d. Title 18 United States Code, Section 609, "Use of Military Authority to Influence Vote of Member of Armed Forces."
- e. Title 42 United States Code, Section 1973ff, "Federal Responsibilities"
- f. DoD Directive 1000.4, "Federal Voting Assistance Program (FVAP)."

Service Policy and Doctrinal Publications: The following Service-specific policy and doctrinal publications provide insight into the rules and doctrine that will assist Joint IGs in the conduct of their duties:

- a. **Army:**
 - (1) Army Regulation 608-20, "Army Voting Assistance Program."
- b. **Navy:**
 - (1) OPNAV Instruction 1742.1, "Navy Voting Assistance Program (NVAP)."
- c. **U.S. Marine Corps:**
 - (1) Marine Corps Order 1742.1A W CH 1-2, "Voter Registration Program."
- d. **U.S. Air Force:**
 - (1) Air Force Instruction (AFI) 36-3107, "Voting Assistance Program."

Appendix C

Conducting Interviews

1. **Purpose:** This appendix outlines a general approach to conducting interviews.
2. **Purpose of Interviews:** An interview is a meeting at which information is obtained from a person. Interviews are designed to allow a Joint IG to gather information through one-on-one, face-to-face contact with an individual. Interviews are not interrogations, which involve questioning a person formally and systematically.
3. **Setting the Conditions for an Interview:** Scheduled interviews often last one hour, but the actual duration will vary based upon the amount of information required. The same notion applies to walk-in interviews. The Joint IG should always conduct the interview in a private place that will be free from interruptions and will readily set the interviewee at ease. If necessary, place "do not disturb" signs on the door or find a place that is free from distracting telephone calls or repeated interruptions by co-workers or subordinates. Always be friendly and personable to the person you are about to interview. This behavior will set the person at ease. For a walk-in interview, greet the person by coming from behind your desk with your hand extended and a smile on your face. Joint IGs may also conduct interviews in pairs; one IG can record the information while the other IG asks the questions.
4. **Introduction:** Scheduled interviews during Inspections will begin with a prepared introduction recited by the Joint IG to the interviewee. This introduction will explain the purpose, scope, and ground rules of the interview. The introduction will also explain the notion of confidentiality and set a prescribed time limit for the interview (see the example at the end of this chapter).
5. **Conducting the Interview:** Immediately following the introduction or read-in briefing, scheduled interviews will continue with the prepared questions (for an Inspection) or interrogatory (for an Investigation). Develop no more than 10 questions since time will not allow for many more. The IG must always ask one question at a time and present the questions in a logical sequence. Give the interviewee enough time to answer each question thoroughly. Do not ask bullying or trick questions. The questions should be open-ended and promote discussion. Close-ended questions, questions that normally require only a yes or no response, will often keep the Joint IG from determining the root cause or deeper meaning of a problem or issue. The Joint IG should ask each question in a friendly yet business-like manner, and the IG should probe for answers only as far as is necessary to obtain the required information. The same principles apply to walk-in interviews, even though the IG will not be using prepared questions to gather information. The following are some helpful hints about conducting interviews:
 - a. **Establish rapport.** Rapport is a relationship built on harmony and will immediately set the interviewee at ease. The interview will proceed well if the interviewee senses the Joint IG is someone with whom he or she can speak easily and comfortably.

b. **Maintain Control**. The Joint IG must always control the interview and not allow the discussion to digress to irrelevant issues. Joint IGs can maintain control without being overly assertive. Instead, the IG can simply keep re-directing the discussion back to the interview's primary topic.

c. **Avoid Arguing**. A Joint IG must not argue with the interviewee even if he or she disagrees strongly with what the person says. The Joint IG's mission is to gather the required information and to remain as neutral as possible.

d. **Maintain Strict Impartiality**. Joint IGs should never make value judgments about the information gathered. In cases where an interviewee misquotes a regulation or standard, the Joint IG can, and should, intercede and correct the error as part of the Joint IG's Teach-and-Train function. Likewise, Joint IGs should not proffer an opinion about anything an interviewee says or commiserate with that person on any real or perceived injustices.

e. **Do Not Try to Solve Problems on the Spot**. Numerous issues and personal problems may arise during the course of scheduled interviews. The interviewee may attempt to solicit the Joint IG for a response or an agreement to fix a problem as soon as possible. This same notion especially applies to walk-in interviews for assistance. In all circumstances, Joint IGs must refrain from attempting to solve a problem on the spot or promising that he or she will get something "fixed" for the interviewee. If the Joint IG is unable to comply with that promise at a later date, the IG's credibility will suffer.

f. **Do Not Allow the Interviewee to Interview You**. If the interviewee begins asking questions of the Joint IG such as "What do you think of this situation?" or "Would you put up with that stuff?", the Joint IG should ignore the queries and continue with the questioning. If the interviewee persists, then the IG should simply state he or she is not familiar enough with the situation to render an opinion. An opinion proffered by a Joint IG may compromise that IG's impartiality at a later date.

g. **Be a Good Listener**. The quality of a Joint IG's listening can actually control another person's ability to talk. Listening is an active process in which the Joint IG thinks ahead, weighs the points, reviews the information already covered, and searches the information for greater meaning. Most people need some feedback to ensure that the Joint IG is being attentive and hearing them. If the Joint IG stares at the responding interviewee impassively, the interviewee will be less forthcoming and feel that what he or she is saying is unimportant. The Joint IG should be a positive listener who uses non-judgmental expressions or gestures that show interest or understanding. A small gesture such as a nod, a smile, or eye contact is often enough to maintain rapport with the interviewee. The Joint IG may also try neutral phrases such as "Tell me more about it" or "Go on and explain what happened next."

h. **Silence**. Silent pauses during an interview should never embarrass a Joint IG. A respect for silence is often helpful and can allow both the interviewer and interviewee to collect their thoughts before proceeding. A hasty interruption on the Joint IG's part may leave an important part of the story forever untold. The Joint IG may also use silence to force a response from a reluctant interviewee. If the IG must ask a lot of questions in order to keep the person providing information, the interview can quickly become an interrogation.

i. **Accept the Interviewee's Feelings.** Joint IGs must learn to accept a person's feelings during an interview and avoid passing judgment on someone. Gather only the facts, and do not dole out false reassurances about anything.

6. **Sample Introduction for a Scheduled Interview:** The following sample introduction is for a scheduled interview conducted as part of an inspection on the Individual Augmentation process:

Individual Augmentation Interview Introduction

Hello, I am _____ of the _____ Inspector General office.

- I am talking to you as part of an inspection that the _____ IG is doing on the Individual Augmentation (IA) process to determine _____. The Commander, _____ Command, directed this inspection.
- I am interviewing you to get your thoughts and opinions about the Individual Augmentation process and its _____. We will combine what you tell us with what others say. We will look for patterns and trends in the collective comments and perceptions and then report that information to the _____ Inspector General and other senior leaders.
- We define Individual Augmentation as: _____(Reference Document).
- This command may describe the program by a different name or term. If so, please let me know. If you do not recognize a term, please ask.
- I want you to feel perfectly at ease and talk freely with me. To this end, I propose these ground rules:
 - I am interested specifically in your thoughts, feelings, opinions, or anything relevant to the subject.
 - I will take notes to capture the essence of what you say. However, I will not use your name or in any way attribute what you say to who you are. I am sensitive to the fact that you might not talk as freely about things if you think your comments could later be attributed to you in a negative way.
 - The only time that I might attribute a name to a statement is in the unlikely event that you indicate that you have evidence of a crime, a security violation, or a serious breach of integrity. If that happens, I will discuss that issue with you immediately following this interview.
 - I will take about one hour of your time.
- Do you have any questions about the ground rules? Great! Let's begin!

Appendix D

Conducting Sensing Sessions

1. **Purpose:** The purpose of this appendix is to provide guidance on how to conduct a sensing session.
2. **Discussion:** Sensing sessions are group interviews that can serve as an excellent source of information. The objective of a sensing session is to provide Joint IGs with the perceptions and opinions of the group's members (Soldiers, Sailors, Airmen, Marines, Coast Guard, and so on). If conducted properly, the group that the team is sensing will feel comfortable and share some critical opinions and observations about a certain topic.

The key to a successful sensing session is to make the group feel comfortable, even though the facilitator may be a lieutenant colonel while the group members are junior enlisted Sailors. The facilitator must not assert his or her authority directly but instead do so in a subtle manner through body language and tone. The sensing-session group will understand that authority if the facilitator conducts the session professionally and treats everyone with equal respect throughout the session. The key features of a successful sensing session are as follows:

- a. **Location:** The setting should be in a classroom-sized environment and preferably away from the unit. The location must support the notion of anonymity since the people you are sensing will expect some measure of confidentiality. The preferred structure of the room is to arrange the chairs into a circle or "U." All participants should be able to see each other. Avoid using a classroom set-up with tables or desks since the participants cannot see each other and the facilitator will have difficulty maintaining eye contact.

- b. **Group Size and Composition:** A successful sensing session cannot occur with fewer than eight (8) people. The preferred group size is 15 since the facilitator cannot maintain eye contact or rapport with a group larger than 15. Groups smaller than eight people will not support, in each participant's mind, the Joint IG's promise of anonymity and will normally devolve into a discussion between the facilitator and one or two of the more outspoken participants.

The unit will select the participants based upon criteria established by the Joint IG. The Joint IG must not, under any circumstances, select the participants by name. The Joint IG should stratify the group by unit, gender, race, and grade as required. The facilitator must not allow members of the group's chain of command to observe the session. Likewise, the facilitator must ensure that none of the group members shares a supervisory relationship with another member.

- c. **Preparation:** The facilitator must develop no more than 10 open-ended questions that will help capture the desired information about the topic. Close-ended questions require yes or no responses and will not allow the Joint IG to get at the root cause of the problem or any other underlying issues.

The facilitator must also consider the group's composition when developing sensing-session questions. The questions the facilitator asks a group of enlisted Marines will vary from the questions posed to a group of junior officers. In addition, the facilitator must know and understand the questions thoroughly. The facilitator must be prepared to allow the discussion to ramble a bit and not simply force the group to answer a series of questions in succession. The facilitator should ultimately ensure the group answers all of the questions but within the context of a free-flowing discussion.

d. **Recording:** Another team member, who will serve as a recorder (or scribe) for the session, must accompany the facilitator. The recorder will take notes to capture the essence of what the group members say without quoting anyone directly. The recorder will never list the names of those present for the session. Also, some situations may occur when the facilitator must also serve as the recorder.

e. **Introduction:** The facilitator must have on hand a prepared introduction or statement that captures the purpose and intent behind the session. Likewise, this introduction must establish ground rules for the session such as confidentiality, actions taken if a person inadvertently gives evidence of a crime, and so on. The introduction must mention that the Joint IG is interested in the group's opinions and perceptions about the topic at hand and that the recorder will only take notes to capture the essence of what the group says but will not take names (see the end of this appendix for a sample introduction).

f. **Conducting the Session:** The session should not last for more than two hours since most of the group members will become fidgety and fatigued by this time. The preferred time for a sensing session is 90 minutes. The facilitator can begin with some humor but should do so only if the comments do not compromise the seriousness or professional nature of the session.

The facilitator should ask the first question and then allow the discussion to develop naturally. Once the facilitator obtains the required information from the group concerning the first question, the facilitator can begin with the next question. Asking the questions in sequence is less important than gathering the required information. A rambling, naturally developing discussion may ultimately answer all of the questions, so the recorder has to know how to capture the relevant information as it surfaces. When the discussion begins to wind down, the facilitator can ask those questions not answered during the larger discussion.

The facilitator must make every effort to involve everyone in the discussion and treat each group member's comments as valid and useful, even if some of the comments may seem strikingly ridiculous. In effect, the facilitator must never "shut out" a participant by evaluating someone's statement in front of the group. The facilitator and the recorder must be good, active listeners and show interest in the comments made by the group's members. The recorder may also interject and ask follow-up questions or request clarification as necessary. The recorder may also summarize the feedback periodically to ensure that he or she has captured the group's thoughts accurately.

Since the sensing session is not a complaint session, the facilitator must remind the group to hold all complaints or personal issues until after the sensing session (if complaints begin to surface). The Joint IG must never make a commitment or a promise during the session, even if pressed to do so by a member of the group.

g. **Ending the Session:** The facilitator should begin ending (or winding down) the session 15 minutes before the scheduled completion time. If the group answers all questions before the time is over, then release the group early. Most of these people will have other things to do and will appreciate the extra time. The facilitator or recorder should summarize the key points made during the session before releasing the group. Be sure to thank them for their assistance and remind them one last time about the issue of confidentiality.

3. **Sample Introduction for a Sensing Session:** The following sample introduction is for a sensing session conducted as part of an inspection on Individual Augmentation:

Individual Augmentation Sensing Session Introduction

Hello, I am _____ of the _____ Inspector General office.
This is my partner, _____.

- We are talking to you as part of an inspection the _____ IG is doing on the _____ to determine _____. The Commander, _____, directed this inspection.
- We are interviewing you to get your thoughts and opinions about _____ and its _____. We will combine what you tell us with what other groups say. We will look for patterns and trends in the collective comments and perceptions and then report that information to the _____ Inspector General and other senior leaders.
- We define Individual Augmentation as _____ (Source Reference).
- Your unit may describe the program by a different name or term. If so, please let us know. If you do not recognize a term, please ask.
- We want you to feel perfectly at ease and talk freely with us. To this end, we propose these ground rules:
 - We are interested specifically in your thoughts, feelings, opinions, or anything relevant to the subject. Speak for yourself and avoid speeches or philosophical statements.
 - Respond to the questions we ask, stay on track, and avoid sidebars with your neighbors.
 - Keep each other's input confidential; what is said in this room stays in this room.
 - My partner will take notes to capture the essence of what you say. We will not use your name or in any way attribute what you say to who you are. We are sensitive to the fact that you might not talk as freely about things if you think your comments could later be attributed to you in a negative way.

- The only time we might attribute a name to a statement is in the unlikely event that you indicate that you have evidence of a crime, a security violation, or a serious breach of integrity. If that happens, we will discuss that issue following this session.
- We will take about one hour and 30 minutes of your time.
- Do you have any questions about the ground rules? Great! Let's begin!

Appendix E

Guidance on Collecting U.S. Person Information

1. **Purpose.** This section provides further information on collecting U.S. person information by addressing some vague areas in E.O. 12333 and other DoD-related Intelligence Oversight documents.

2. **Respect for Legal Rights of United States Persons (U.S. persons).** These guidelines do not authorize maintaining information on U.S. persons solely for the purpose of monitoring activities protected by the First Amendment or the lawful exercise of other rights secured by the Constitution or laws of the United States. Rather, all activities conducted under these guidelines must have a valid purpose and must be carried out in conformity with these guidelines; all applicable statutes; Executive Orders; and Department of Defense directives, regulations, and policies. In particular, DoD intelligence component personnel are required to ensure that all intelligence activities that require the collection, retention, and dissemination of information about United States persons are done in a manner consistent with Executive Order 12333, DoDD 5240.1, DoD 5240.1-R, and any DoD or military service implementing guidance on intelligence activities.

3. **Determination of United States Person Status.** A United States person is:
 - a. An individual who is a United States citizen or an alien lawfully admitted for permanent residence;
 - b. An unincorporated association substantially composed of individuals who are United States persons; or
 - c. A corporation incorporated in the United States.
 - d. If we do not have information indicating that the person is an alien or not legally residing in the United States, that person's status will be considered unknown. Once classified as an unknown status, subjects within the United States are assumed to be U.S. persons; subjects outside of the United States are assumed not to be U.S. persons.

4. **Collecting U.S. Person Information.** Information may be collected by pulling the information from sources (accessing it) or having it pushed by sources to intelligence components or personnel (receiving it). DoD 5240.1-R, Procedure 2, defines collection as the receipt of information for use by an employee of a DoD intelligence component in the course of his / her official duties. Essentially, this description means that information is collected when received by a DoD intelligence component employee with the intent to use the information in some manner. Data acquired by electronic means would not be considered "collected" until it has been processed into intelligible form. So, as an example, encrypted signal intelligence (SIGINT) data in bits and bytes would not be considered "collected" until unencrypted and produced in a useable form; however, a written report, spreadsheet, or database received through electronic means (such as an e-mail or electronic database query) would be considered in intelligible form once received for use or further analysis, even if it has not yet been subjected to analysis to

determine its intelligence value. DoD intelligence components and personnel may collect, through access or receipt, information held by any source, in any format, subject to the following caveats. Before collecting information, DoD intelligence component personnel must have the appropriate clearance and a valid mission requirement to review the information. Further, DoDD 5240.1 limits permissible intelligence activities of DoD intelligence components to foreign intelligence (FI) and counterintelligence (CI). Information about U.S. persons may be intentionally collected from all available permissible sources only when it is either FI or CI and necessary to the conduct of the specific DoD intelligence component's mission and responsibility and falls within one of the specific 13 categories of U.S. person information specified in DoD 5240.1-R, Procedure 2.

5. Processing and Safeguarding United States Person Information.

a. Before using any information accessed or received by DoD intelligence components, the user shall review it to determine whether the information identifies a U.S. person as defined in these guidelines.

b. United States persons identifying data includes a name, Social Security Number, or Alien Registration number. Depending on what other information is available, U.S. person identifying data may also include date and place of birth and permanent address, vehicle license plates, or similar information.

c. Information about U.S. persons may be retained only if collected properly. Collection may occur intentionally or incidentally. Intentionally collected information is only permitted if authorized under DoD 5240.1-R, Procedure 2, and is expected to fall within one of the 13 specifically enumerated categories:

- (1) information obtained with consent;
- (2) publicly available information;
- (3) foreign intelligence;
- (4) counterintelligence;
- (5) potential sources of assistance to intelligence activities;
- (6) protection of intelligence sources and methods;
- (7) physical security where there is a reasonable belief that a foreign nexus exists;
- (8) personnel security;
- (9) communications security;
- (10) narcotics;
- (11) threats to safety where there is a reasonable belief that a foreign nexus exists;
- (12) overhead reconnaissance; or
- (13) administrative purposes (See DoD 5240.1-R, Procedure 2, for definitions).

If the information was incidentally collected (that is, not intentionally accessed or received), it should be reviewed to ensure that it could have been intentionally collected under DoD 5240.1-R, Procedure 2, or may otherwise be retained in accordance with DoD 5240.1-R, Procedure 3. DoD intelligence component personnel may temporarily retain all collected information on U.S. persons for up to 90 days solely to review and determine if it was properly collected and therefore may be permanently retained. This temporary retention period begins the moment that a DoD intelligence component employee receives or retrieves U.S. person information in the course of his or her official duties with the intent of determining whether the information should be used in a report, a database, or in some other manner that constitutes an affirmative intent to use or retain the information. Once a collectability determination has been made regarding information received or retrieved on U.S. persons, if the information should not have been collected, or is not needed, it will be destroyed immediately.

d. All information received or retrieved by DoD intelligence components or personnel subject to this instruction that is temporarily retained while pending a collectability determination for permanent retention shall be segregated from other U.S. person information for which a collectability determination has been made authorizing permanent retention. All U.S. person information temporarily retained pending a permanent retention collectability determination shall be regularly reviewed periodically, not to exceed a 90-day period, to ensure that U.S. person information is not improperly retained.

e. All Combatant Command records or documents (regardless of format), produced, retained, or disseminated by DoD intelligence components or personnel subject to this instruction that contain U.S. person identifying data shall be clearly marked "CONTAINS U.S. PERSON INFORMATION", "THIS REPORT CONTAINS U.S. PERSON IDENTITY INFORMATION", "USPERSON", etc., as appropriate.

f. Prior to dissemination, all COCOM or component intelligence products will be reviewed to determine whether the U.S. person identity information is necessary for the use of or the understanding of the product. This process is called the MINIMIZATION process. Where the U.S. person identity information is not necessary to understand the product, the identity information will be MINIMIZED by replacing it with "a U.S. person", "USPER", "a U.S. hydroelectric corporation", "a Colorado social club" etc., as appropriate.

g. Where a COCOM or component intelligence product will include U.S. person identity information, the product will carry a warning stating that "This product contains U.S. person information" or words to that effect. Where U.S. person information has been minimized, the product will carry a notice to that effect and will clearly advise the recipients how they may obtain the U.S. person identity data should their mission require it. Additionally, a marking that clearly indicates that the information is considered U.S. person information must follow the first reference to each U.S. person's identity. For example: "(U.S. PERSON)" or "(USPER)."

h. On occasion, it may be appropriate to produce and disseminate multiple versions of a product with varying degrees of U.S. person identifying information included, based upon the respective intended audience for each product.

6. Collectability and Retention Determinations for U.S. persons (Establishing a “Foreign” or “Transnational” Nexus). The conduct of intelligence activities (foreign intelligence or counterintelligence) by DoD intelligence components requires establishing a foreign or transnational nexus to collect information about U.S. persons. There must be a reasonable belief that the U.S. person is working for or on behalf of, under the control of, or an agent of, a foreign power or international terrorist organization or is involved in international narcotics activities. When determining if a sufficient foreign or transnational nexus exists to warrant permanent retention of U.S. person information, all facts and circumstances should be evaluated in making the collectability and permanent retention determination.

The following list provides some of the factors helpful in making this determination:

- a. Evidence of direct communications to or from known international terrorists or international terrorist organizations, foreign powers, or international narcotics organizations indicating direction or control of the U.S. organization.
- b. Evidence indicating that U.S. persons have visited, communicated with, or downloaded material from web sites operated by or under the control of known international terrorist organizations.
- c. Evidence of membership in known international terrorist or international terrorist organizations, foreign powers, or international narcotics organizations indicating direction or control of the U.S. organization.
- d. Evidence indicating allegiance to international terrorist organizations or adoption of international terrorist ideology by the U.S. person.
- e. Acts conducted by U.S. persons in furtherance of stated goals or objectives of known international terrorist organizations.
- f. Participation in training conducted by or under the direction of known international terrorist organizations.
- g. Evidence of solicitation of financing or receipt of financing from foreign sources.

7. When evaluation of all available facts does not clearly support a reasonable belief that the U.S. person has sufficient foreign or transnational nexus to support permanent retention, a collectability determination should be sought in writing from the organization’s servicing legal advisor. Ensure that this collectability determination is sought sufficiently in advance of the 90-day limit to make a determination on permanent retention by or before 90 days.

Appendix F

Sample QIA and Quarterly Reporting Format and Instructions

1. **Purpose.** This section provides instructions and an example memorandum for submitting a Quarterly IO Report to the Joint Staff IG.
2. **Report Submission.** DoD components assigned to conduct intelligence and counterintelligence activities shall submit reports to the Joint Staff Deputy Inspector General (JS DIG) in accordance with the following guidance. JS DIG will compile all quarterly reports from Joint IGs and submit the report to ATSD (IO).
 - a. Report questionable intelligence activities of a serious nature and all significant or highly sensitive matters immediately. Such reports may be by any secure means. Verbal reports should be documented with a written report as soon as possible thereafter.
 - b. Report questionable intelligence activities not of a serious nature quarterly. Reporting periods shall be based on the calendar year. The first report for each calendar year shall cover January 1 through March 31. Succeeding reports shall follow at 3 month intervals. Quarterly reports are due to the JS DIG no later than 5 working days after the beginning of each quarter (Oct, Jan, Apr, July). Quarterly reports will describe all questionable intelligence activities as well as significant or highly sensitive matters identified during the quarter. Quarterly reports are required even if no reportable matters occurred during the reporting period.
 - c. Reporting DoD components will format the report as follows:
 - (1) **Assignment of a Case Number for Each Incident.** Except where the volume of incident investigations, that have been reported and closed within the same reporting quarter, make the assigning of a case number impracticable, a case number that runs consecutively and identifies the reported incident by reporting agency, military department, or combatant command and calendar year shall be assigned to each incident.

For example: **DIA 2009-04**

This number indicates the fourth incident reported by the Defense Intelligence Agency (DIA) in calendar year 2009. Use this number each time the incident is mentioned in initial reports and in update and close-out reports. A case number will be assigned to all reported incidents that, at a minimum, are the subject of an ongoing investigation.

- (2) Information to be Included in each report. For each incident reported, include the following information as it becomes available.
 - (a) A narrative describing each incident reported.
 - (b) An explanation of why the incident is being reported either as a potential violation of law, potentially contrary to Executive Order or Presidential Directive, or

a potential violation of DoD 5240.1-R and/or military department procedures implementing E.O. 12333. Cite the portions of relevant law, order, policy, or regulation as it is determined.

(c) An explanation of why the incident is considered a significant or highly sensitive matter, if so reported.

(d) An analysis of how or why the incident occurred.

(e) An assessment of the anticipated impact of the reported incident on national security or international relations, as well as any mitigation efforts, including success and failures of such efforts. If there has been no impact or no impact is anticipated, the report should so state.

(f) Remedial action taken or planned to prevent recurrence of the incident.

(g) An assessment of any impact the reported incident may have on civil liberties or protected privacy rights.

(h) A description of actions taken if the incident concerns information improperly acquired, handled, used, or destroyed,

(i) Any additional information considered relevant for purposes of fully informing the Secretary and/or Deputy Secretary of Defense, the Intelligence Oversight Board (IOB), and the Director of National Intelligence (DNI) and providing context about the incident.

d. Reporting should not be delayed or postponed pending an investigation, command inquiry, or legal proceeding.

Sample memorandum formats are on the next pages.

Sample Quarterly Report

Classification: SENSITIVE BUT UNCLASSIFIED

DRAFT SAMPLE REPORT

COCOMIG
6 April 2009

MEMORANDUM FOR RECORD

SUBJECT: Quarterly Intelligence Oversight Report-1st Quarter, 20XX

References.

- a. Listed as required.
1. Introductory content as required by the reporting component.
2. New Incidents.
 - a. Case Number.
 - (1) A narrative describing the incident reported.
 - (2) An explanation of why the incident is being reported either as a potential violation of law, potentially contrary to e Executive Order or Presidential directive, a potential violation of reference (XX)d, or a violation of agency or military department procedures. Cite the portions of relevant law, order, policy, or regulation as it is determined.
 - (3) An explanation of why the incident is considered a significant or highly sensitive matter if so reported.
 - (4) An analysis of how or why the incident occurred.
 - (5) An assessment of the anticipated impact of the reported incident on national security or international relations, as well as any mitigation efforts, including success and failures of such efforts. If there has been no impact or no impact is anticipated, the report should so state.
 - (6) Remedial action taken or planned to prevent recurrence of the incident.
 - (7) An assessment of any impact the reported incident may have on civil liberties or protected privacy rights.
 - (8) A description of actions taken if the incident concerns information improperly acquired, handled, used, or destroyed.

(9) Any additional information considered relevant for purposes of fully informing the Secretary and/or Deputy Secretary of Defense, the IOB, and the DNI and providing context about the incident.

b. Case Number.

(1)

(2)

3. Updates on Previously Reported Incidents. The format for this paragraph will follow that indicated for paragraph 2 and will address incidents still under inquiry as well as those resolved and closed during the quarter.

4. This paragraph will contain a summary of the gravity, frequency, trends and patterns of the questionable intelligence activities and/or significant or highly sensitive incidents reported during that quarter, to the extent that they can be determined. Otherwise, the summary should be provided, as the information becomes available, in a subsequent quarterly report.

5. This paragraph will include a description of any inspection findings or intelligence oversight program developments, such as publication of a revised intelligence oversight regulation that the reporting DoD Component believes is significant. Neither training reports nor inspection schedules shall be included in the quarterly report to ATSD(IO).

6. Additional paragraphs as required by the reporting Component.

[Signature]

ENCLOSURES

May include:

Summary of 15-6 for closed cases

Copy of revised DOD Component significant IO regulations

Classification: UNCLASSIFIED

Sample QIA Report

Classification: SENSITIVE BUT UNCLASSIFIED

COCOMIG
6 April 2009

MEMORANDUM FOR: DEPUTY INSPECTOR GENERAL, JOINT STAFF (ATTN:
Name here)

SUBJECT: Initial Questionable Intelligence Activity/Procedure 15 Report on

1. COCOM NAME 2009-##: (Example: SOCOM 2009-01)
 - a. A narrative describing the incident reported.
 - b. An explanation of why the incident is being reported either as a potential violation of law, potentially contrary to Executive order of Presidential directive of potential violation of DOD 5240.1-R and/or agency or military department procedures implementing E.O. 12333. Cite the portions of relevant law order, policy or regulation as it is determined.
 - c. An explanation of why the incident is considered a significant or highly sensitive matter.
 - d. An analysis of how or why the incident occurred
 - e. Assessment of anticipated impact of the reported incident on national security or international relations. If there is no impact or no impact anticipated, the report should state so.
 - f. Remedial action taken or planned to prevent recurrence of the incident.
 - g. An assessment of any impact the reported incident may have on civil liberties or protected privacy rights.
 - h. Description of any actions taken if the incident concerns information improperly acquired, handled, used or destroyed.
 - i. Any additional info considered relevant for purposes of fully informing the Secretary and/or DEPSECDEF, the IOB and the DNI and providing context about the incident.

Signature BLOCK

ENCLOSURES

Classification: UNCLASSIFIED

Index

- Applicability, 9-3
- Baseline Methodology, 5-19
- Briefing Contents, 7-3
- Briefing Outline, 6-20
- Commander's Approval, 7-3
- Commander's Cover Letter, 7-5
- Communications, 2-6
- Completion Phase, 7-1
 - Briefing Contents, 7-3
 - Commander's Approval, 7-3
 - Commander's Cover Letter, 7-5
 - Final Report Distribution, 7-7
 - Finalizing Written Report, 7-5
 - Follow-up Inspections, 7-8
 - Handoff, Definition, 7-6
 - Handoff Procedures, 7-6
 - Issuing Taskers, 7-4
 - Joint IG Role in Taskers, 7-4
 - Out-Briefing the Commander, 7-3
 - Release Authority, 7-7
 - Releasing IG Records, 7-7
 - Submit Final Report to Joint Commander, 7-5
- Compliance Inspection, 8-1
 - Checklists, 8-5
 - Definition, 8-2
 - Methodology, 8-3
 - Process, 8-3
 - Sample Checklist, 8-7
- Concept Approval Briefing, 5-10
 - Develop, 5-10
 - Sample, 5-10
- Conducting Interviews, Appendix C
- Conducting IPR, 6-10
- Conducting Pre-inspection Visit, 5-40
- Conducting Sensing Sessions, Appendix D
- Confidentiality, 9-8
- Cross-walking, 6-21
- Detailed Inspection Plan, 5-25
- Determining Inspection Topics, 3-12
- Develop Inspection Concept, 5-8
- Developing a Finding Statement, Nine-Step Process, 6-23
- Developing Information-Gathering Tools, 5-33
- Developing Methodology, 5-19
- Developing Out-brief, 6-12
- Developing Sub-tasks, 5-17
- Developing Trends and Patterns, 6-18

- DOTMLPF Analysis, 5-6
- Duties of Temporary IG, 5-32
- Execution Phase, 6-1
 - Actions Following Visit, 6-3
 - Briefing Outline, 6-20
 - Conducting IPR, 6-10
 - Cross-walking, 6-21
 - Developing Out-brief, 6-12
 - Developing Trends and Patterns, 6-18
 - Draft Final Report, 6-21
 - Final Report Format, 6-21
 - Identifying the Proponent, 6-32
 - In-Process Review (IPR), 6-8
 - Information Source, 6-20
 - IPR Analysis Tools, 6-8
 - IPR Worksheet, 6-9
 - Nine-step Process for Developing a Finding Statement, 6-23
 - Out-briefing the Proponent, 6-32
 - Purpose of the Briefing, 6-33
 - Sample Trip Report, 6-5
 - Task Organizing Inspection Team, 6-22
 - Trends Analysis Worksheet, 6-9
 - Updating the Commander, 6-20
 - Visit units, 6-3
 - Writing an Objective Chapter, 6-23
 - Writing Trip Report, 6-4
- Federal Voting Assistance Program Policy, 9-14
- Final Report Distribution, 7-7
- Final Report Format, 6-21
- Finalizing Written Report, 7-5
- Five Elements of an Inspection, 3-17
- Five-Why Analysis, 3-12
- Follow-up Inspections, 7-8
- Function Modeling, 5-4
- Glossary, Appendix A
- Guidance on Collecting U.S. Persons Information, Appendix E
- Handoff, Definition, 7-6
- Handoff Procedures, 7-6
- Identifying the Proponent, 6-32
- In-Briefing and Out-Briefing Formats, 5-36
- In-Process Review (IPR), 6-8
- Inspection Approaches, 3-15
 - Structural Approach, 3-15
 - Systems Approach, 3-16
- Inspection Concept Letter, 5-9
- Inspection Directive, 5-15
- Inspection Process, 4-1
 - Three Phases, 4-1
 - Inspections Process Flow Chart, 4-2
- Inspections Selection Process, 3-13
 - Determining Joint Commander's Priorities, 3-13

- Analyze the Information, 3-13
- Make Prioritized List, 3-13
- Gain Commander's Approval, 3-13
- Schedule Inspections, 3-13
- Notify Command, 3-14
- Intelligence personnel reporting requirements, 9-9
- Internal Control, 9-12
- Internal Control Standards, 9-12
- Interview and Sensing Session Rehearsal, 5-38
- Introduction to Inspections Guide, 1-1
- IPR Analysis Tools, 6-8
- IPR Worksheet, 6-9
- Issuing Taskers, 7-4
- Joint and Expeditionary Mindset, 2-5
- Joint IG
 - Communications, 2-6
 - Policy Guidance, 2-5
 - Staffing, 2-5
- Joint IG Role in Taskers, 7-4
- Joint IG Reporting Requirements, 9-9
- Joint Operating Environment, 2-7
- Joint Training and Readiness, 2-9
- Nine-step Process for Developing a Finding Statement, 6-23
- Notification Memorandum, 5-22
- Notifying Units or Commands Selected for Pre-Inspection Visit, 5-40
- Out-briefing the Proponent, 6-32
- Personnel Accountability Reporting System, 9-11
- Policy Guidance, 2-5
- Policy Guidance for Intelligence Oversight, 9-3
- Preparation Phase, 5-1
 - Additional Training, 5-32
 - Concept-Approval Briefing, 5-10
 - Conducting Pre-inspection, 5-40
 - Detailed Inspection Plan, 5-25
 - Develop Inspection Concept, 5-8
 - Developing Information-Gathering Tools, 5-33
 - Developing Methodology, 5-19
 - Developing Sub-tasks, 5-17
 - Duties of Temporary IG, 5-32
 - Equipment Inventory and Rehearsal, 5-38
 - In-Briefing and Out-Briefing Formats, 5-37
 - Inspection Directive, 5-15
 - Interview and Sensing Session Rehearsal, 5-38
 - Observation Spot Report, 5-35
 - Notification Memorandum, 5-20
 - Notifying Units or Commands Selected for Pre-Inspection Visit, 5-40
 - Planning in Detail, 5-17
 - Purpose and objectives, 5-3
 - Purpose of Pre-inspection Visit, 5-40
 - Refining Methodology, 5-40
 - Research, 5-3

- Sample Concept Approval Briefing, 5-10
- Sample Detailed Inspection Plan, 5-28
- Sample Inspection Concept Letter, 5-9
- Sample Inspection Directive, 5-16
- Sample FRAG Order, 5-23
- Sample Interview Questions, 5-34
- Sample Inspection Notification Memorandum, 5-22
- Sample Sensing Session Questions, 5-35
- Selecting Unit for Pre-inspection, 5-40
- Training for the Inspection, 5-32
- Purpose of Pre-inspection Visit, 5-40
- Quality Standards for Inspections, 3-2
- Records Release, 9-8
- References, Appendix B
- Release Authority, 7-7
- Releasing IG Records, 7-7
- Reporting Matrix, 9-7
- Reporting Requirements, 9-6
- Required Release, 9-8
- Research, 5-3
- Responsibilities of a Joint IG, 2-2
- Responsibilities of the Joint IG Intelligence Oversight Program, 9-4
- Risk Assessment, 9-12
- Roles of a Joint IG, 2-2
- Root Cause Analysis, 3-18
 - Five-Why Analysis, 3-22
 - Root Cause Analysis Model, 3-18
 - Root Cause Analysis Model Flow Chart, 3-21
 - Two Forms of Root Causes, 3-18
 - Using Root Cause Analysis Model, 3-19
- Sample Concept Approval Briefing, 5-10
- Sample Detailed Inspection Plan, 5-28
- Sample Inspection Concept Letter, 5-9
- Sample Inspection Directive, 5-16
- Sample FRAG Order, 5-23
- Sample Interview Questions, 5-34
- Sample Memorandum for the Record, 6-5
- Sample Notification Memorandum, 5-22
- Sample QIA and Quarterly Reporting Format and Instructions, Appendix F
- Sample Sensing Session Questions, 5-35
- Selecting Inspections, 3-12
- Selecting Unit for Pre-inspection, 5-40
- Staffing, 2-5
- Structural Approach, 3-15
- Submit Final Report to Joint Commander, 7-5
- Systems Approach, 3-16
- Task Organizing Inspection Team, 6-22
- Training for the Inspection, 5-32
- Training Requirements, 9-7
- Trends Analysis Worksheet, 6-9
- Two Forms of Root Causes, 3-17

Universal Joint Task List (UJTL), 2-8
Updating the Commander, 6-20
Using Root Cause Analysis Model, 3-9
Writing an Objective Chapter, 6-23
Writing Trip Report, 6-4